

Update

ZCC-CT

HPC Endmills HPC Fräser

**High Performance Solide Carbide Endmills
Hochleistungs-VHM-Fräser**



ZCC Cutting Tools Europe GmbH

HPC Endmills / HPC Fräser

- Unique geometry design with 38°/41° helix angle in optimal combination of top grade, KMG 405.
 - Suitable for roughing and finishing of steel, alloy steel and stainless steel, heat resistance super alloy.
 - Effective milling with higher feed rate and bigger cutting depth.
 - Quiet machining without vibration.
 - Long tool life and good surface finishing.
- Einzigartige Geometrie mit ungleichem Spiralwinkel (38°/41°), in Kombination mit der Hochleistungsstufe KMG 405.
 - Geeignet zur Schrupp- und Schlichtbearbeitung von Stahl, legiertem Stahl, rostfreiem Stahl, und warmfesten Superlegierungen.
 - Effektive Fräsbearbeitung mit höheren Vorschüben und größeren Schnitttiefen.
 - Ruhige Bearbeitung ohne Vibrationen.
 - Höhere Standzeit und bessere Oberflächenqualität.



5501R38414GM

4-flute end mills

4-Schneiden VHM Schafffräser

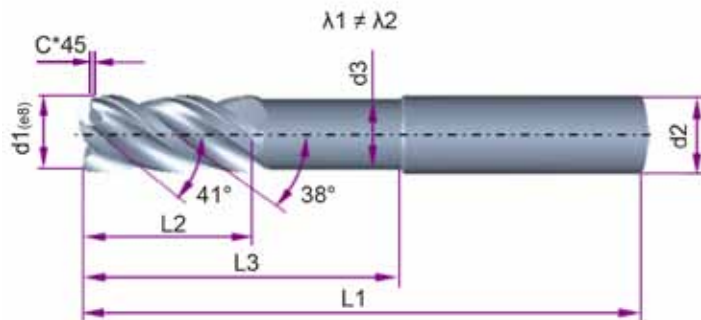
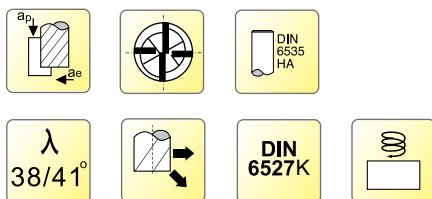

Type Typ	Dimension(mm) Abmessungen							Teeth Zähne Z	Application Anwendung Grade Sorte	Material			
	d1(e8)	d2(h6)	L1	L2	d3	L3	C*45°			P	M	K	S
5501R38414GM-0400	4	6	54	8	4.05	10	0.01-0.06	4			●		
5501R38414GM-0500	5	6	54	9	5.05	11	0.01-0.06	4			●		
5501R38414GM-0600	6	6	54	10	5.70	18	0.06-0.10	4			●		
5501R38414GM-0800	8	8	58	12	7.70	22	0.06-0.10	4			●		
5501R38414GM-1000	10	10	66	14	9.50	26	0.06-0.10	4			●		
5501R38414GM-1200	12	12	73	16	11.50	28	0.10-0.15	4			●		
5501R38414GM-1400	14	14	75	18	13.50	30	0.10-0.15	4			●		
5501R38414GM-1600	16	16	82	22	15.50	34	0.10-0.15	4			●		
5501R38414GM-1800	18	18	84	24	17.50	36	0.10-0.15	4			●		
5501R38414GM-2000	20	20	92	26	19.50	42	0.15-0.20	4			●		

Material Overview · Material Übersicht

✓ = Very suitable · Sehr empfohlen
 ✓ = Suitable · Empfohlen

Workpiece material Werkstückstoff											
Carbon steel Kohlenstoff- Stahl	Alloy steel Legierter Stahl	Hardened steel Gehärteter Stahl				Stainless steel · Rostfreier Stahl	Cast iron, Nodular cast iron Grauguss GGG	Copper alloy Kupfer Leg.	Aluminum alloy Alu. Leg.	Titanium alloy Titan Leg.	Heat resist. alloy Warmfeste Leg.
		~40HRC	~50HRC	~60HRC	~68HRC						
✓	✓	✓	✓			✓	✓			✓	✓

KMG405

5502R38414GM

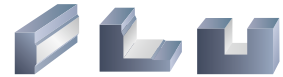

4-flute end mills
4-Schneiden VHM Schafffräser

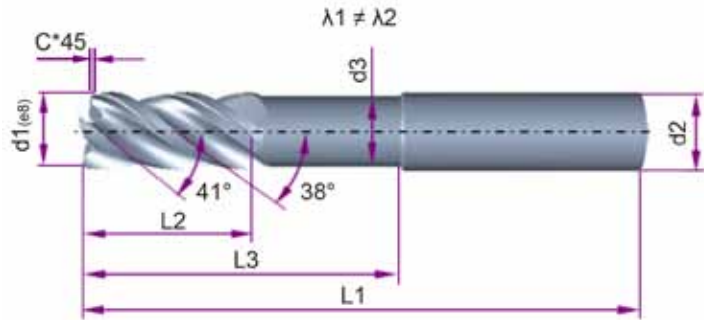
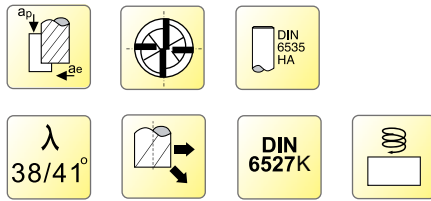

Type · Typ	Dimension(mm) Abmessungen							Teeth Zähne	Applicaion Anwendung	P M K S			
	d1(e8)	d2(h6)	L1	L2	d3	L3	C*45°			Grade Sorte	KMG 405		
5502R38414GM-0400	4	6	57	11	4.05	13	0.01-0.06	4					●
5502R38414GM-0500	5	6	57	13	5.05	15	0.01-0.06	4					●
5502R38414GM-0600	6	6	57	13	5.70	21	0.06-0.10	4					●
5502R38414GM-0800	8	8	63	19	7.70	27	0.06-0.10	4					●
5502R38414GM-1000	10	10	72	22	9.50	32	0.06-0.10	4					●
5502R38414GM-1200	12	12	83	26	11.50	38	0.10-0.15	4					●
5502R38414GM-1400	14	14	83	26	13.50	38	0.10-0.15	4					●
5502R38414GM-1600	16	16	92	32	15.50	44	0.10-0.15	4					●
5502R38414GM-1800	18	18	92	32	17.50	44	0.10-0.15	4					●
5502R38414GM-2000	20	20	104	38	19.50	54	0.15-0.20	4					●

Material Overview · Material Übersicht

✓ = Very suitable · Sehr empfohlen
✓ = Suitable · Empfohlen

KMG405

		Workpiece material Werkstückstoff									
Carbon steel Kohlenstoff- Stahl	Alloy steel Legierter Stahl	Hardened steel Gehärteter Stahl				Stainless steel · Rostfreier Stahl	Cast iron, Nodular cast iron Grauguss GGG	Copper alloy Kupfer Leg.	Aluminum alloy Alu. Leg.	Titanium alloy Titan Leg.	Heat resist. alloy Warmfeste Leg.
		~40HRC	~50HRC	~60HRC	~68HRC						
✓	✓	✓	✓			✓	✓			✓	✓

5502R38414GM-R



4-flute end mills with radius
4-Schneiden VHM Schafffräser mit Radius

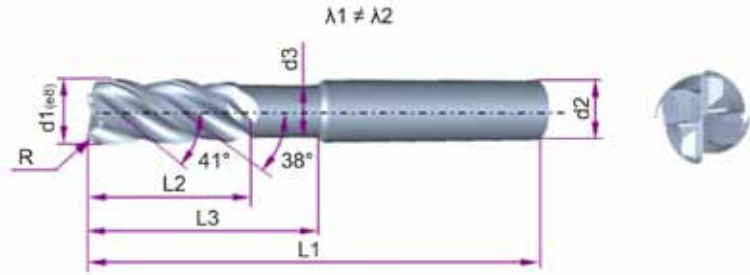
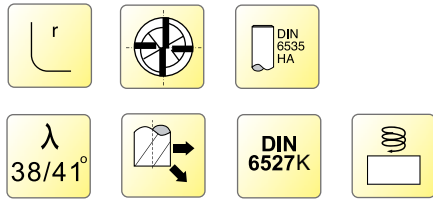

Type · Typ	Dimension(mm) Abmessungen							Teeth Zähne	Application Anwendung	Grade Sorte	P M K S
	d1(e8)	R±0.01	d2(h6)	L1	L2	d3	L3				
5502R38414GM-R02-0400	4	0.2	6	57	11	4.05	13	4		•	
5502R38414GM-R05-0400	4	0.5	6	57	11	4.05	13	4		•	
5502R38414GM-R02-0500	5	0.2	6	57	13	5.05	15	4		•	
5502R38414GM-R05-0500	5	0.5	6	57	13	5.05	15	4		•	
5502R38414GM-R02-0600	6	0.2	6	57	13	5.70	21	4		•	
5502R38414GM-R05-0600	6	0.5	6	57	13	5.70	21	4		•	
5502R38414GM-R10-0600	6	1.0	6	57	13	5.70	21	4		•	
5502R38414GM-R02-0800	8	0.2	8	63	19	7.70	27	4		•	
5502R38414GM-R05-0800	8	0.5	8	63	19	7.70	27	4		•	
5502R38414GM-R10-0800	8	1.0	8	63	19	7.70	27	4		•	
5502R38414GM-R15-0800	8	1.5	8	63	19	7.70	27	4		•	
5502R38414GM-R20-0800	8	2.0	8	63	19	7.70	27	4		•	
5502R38414GM-R02-1000	10	0.2	10	72	22	9.50	32	4		•	
5502R38414GM-R05-1000	10	0.5	10	72	22	9.50	32	4		•	
5502R38414GM-R10-1000	10	1.0	10	72	22	9.50	32	4		•	
5502R38414GM-R15-1000	10	1.5	10	72	22	9.50	32	4		•	
5502R38414GM-R20-1000	10	2.0	10	72	22	9.50	32	4		•	
5502R38414GM-R05-1200	12	0.5	12	83	26	11.50	38	4		•	
5502R38414GM-R10-1200	12	1.0	12	83	26	11.50	38	4		•	
5502R38414GM-R15-1200	12	1.5	12	83	26	11.50	38	4		•	
5502R38414GM-R20-1200	12	2.0	12	83	26	11.50	38	4		•	
5502R38414GM-R10-1600	16	1.0	16	92	32	15.50	44	4		•	
5502R38414GM-R15-1600	16	1.5	16	92	32	15.50	44	4		•	
5502R38414GM-R20-1600	16	2.0	16	92	32	15.50	44	4		•	
5502R38414GM-R30-1600	16	3.0	16	92	32	15.50	44	4		•	
5502R38414GM-R10-2000	20	1.0	20	104	38	19.50	54	4		•	
5502R38414GM-R15-2000	20	1.5	20	104	38	19.50	54	4		•	
5502R38414GM-R20-2000	20	2.0	20	104	38	19.50	54	4		•	
5502R38414GM-R30-2000	20	3.0	20	104	38	19.50	54	4		•	

Material Overview · Material Übersicht

✓ = Very suitable · Sehr empfohlen
✓ = Suitable · Empfohlen

KMG405

Workpiece material Werkstückstoff											
Carbon steel Kohlenstoff. Stahl	Alloy steel Legierter Stahl	Hardened steel Gehärteter Stahl				Stainless steel · Rostfreier Stahl	Cast iron, Nodular cast iron Grauguss GGG	Copper alloy Kupfer Leg.	Aluminum alloy Alu. Leg.	Titanium alloy Titan Leg.	Heat resist. alloy Warmfeste Leg.
		~40HRC	~50HRC	~60HRC	~68HRC						
✓	✓	✓	✓			✓	✓			✓	✓

5602R38414GM



- 4-flute end mills
- 4-Schneiden VHM Schafffräser

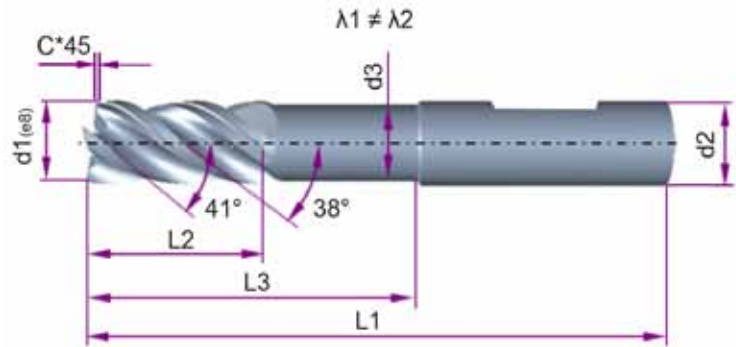
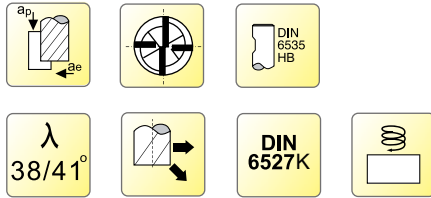

Type · Typ	Dimension(mm) Abmessungen							Teeth Zähne	Application Anwendung	P	M	K	S
	d1(e8)	d2(h6)	L1	L2	d3	L3	C*45°	Z	Grade Sorte	KMG 405			
5602R38414GM-0400	4	6	57	11	4.05	13	0.01-0.06	4					●
5602R38414GM-0500	5	6	57	13	5.05	15	0.01-0.06	4					●
5602R38414GM-0600	6	6	57	13	5.70	21	0.06-0.10	4					●
5602R38414GM-0800	8	8	63	19	7.70	27	0.06-0.10	4					●
5602R38414GM-1000	10	10	72	22	9.50	32	0.06-0.10	4					●
5602R38414GM-1200	12	12	83	26	11.50	38	0.10-0.15	4					●
5602R38414GM-1400	14	14	83	26	13.50	38	0.10-0.15	4					●
5602R38414GM-1600	16	16	92	32	15.50	44	0.10-0.15	4					●
5602R38414GM-1800	18	18	92	32	17.50	44	0.10-0.15	4					●
5602R38414GM-2000	20	20	104	38	19.50	54	0.15-0.20	4					●

Material Overview · Material Übersicht

- ✓ = Very suitable · Sehr empfohlen
- ✓ = Suitable · Empfohlen

KMG405

Workpiece material Werkstückstoff											
Carbon steel Kohlenstoff- Stahl	Alloy steel Legierter Stahl	Hardened steel Gehärteter Stahl				Stainless steel · Rostfreier Stahl	Cast iron, Nodular cast iron Grauguss GGG	Copper alloy Kupfer Leg.	Aluminum alloy Alu. Leg.	Titanium alloy Titan Leg.	Heat resist. alloy Warmfeste Leg.
		~40HRC	~50HRC	~60HRC	~68HRC						
✓	✓	✓	✓			✓	✓			✓	✓

5602R38414GM-R

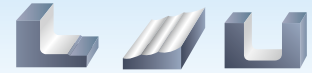

4-flute end mills with radius
4-Schneiden VHM Schafffräser mit Radius

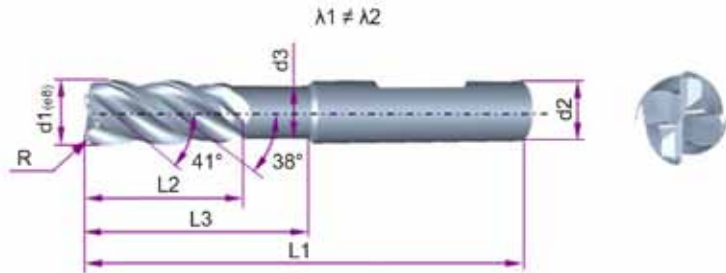
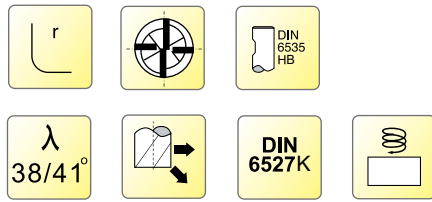

Type · Typ	Dimension(mm) Abmessungen							Teeth Zähne	Application Anwendung	Grade Sorte	P M K S
	d1(e8)	R±0.01	d2(h6)	L1	L2	d3	L3				
5602R38414GM-R02-0400	4	0.2	6	57	11	4.05	13	4		•	
5602R38414GM-R05-0400	4	0.5	6	57	11	4.05	13	4		•	
5602R38414GM-R02-0500	5	0.2	6	57	13	5.05	15	4		•	
5602R38414GM-R05-0500	5	0.5	6	57	13	5.05	15	4		•	
5602R38414GM-R02-0600	6	0.2	6	57	13	5.70	21	4		•	
5602R38414GM-R05-0600	6	0.5	6	57	13	5.70	21	4		•	
5602R38414GM-R10-0600	6	1.0	6	57	13	5.70	21	4		•	
5602R38414GM-R02-0800	8	0.2	8	63	19	7.70	27	4		•	
5602R38414GM-R05-0800	8	0.5	8	63	19	7.70	27	4		•	
5602R38414GM-R10-0800	8	1.0	8	63	19	7.70	27	4		•	
5602R38414GM-R15-0800	8	1.5	8	63	19	7.70	27	4		•	
5602R38414GM-R20-0800	8	2.0	8	63	19	7.70	27	4		•	
5602R38414GM-R02-1000	10	0.2	10	72	22	9.50	32	4		•	
5602R38414GM-R05-1000	10	0.5	10	72	22	9.50	32	4		•	
5602R38414GM-R10-1000	10	1.0	10	72	22	9.50	32	4		•	
5602R38414GM-R15-1000	10	1.5	10	72	22	9.50	32	4		•	
5602R38414GM-R20-1000	10	2.0	10	72	22	9.50	32	4		•	
5602R38414GM-R05-1200	12	0.5	12	83	26	11.50	38	4		•	
5602R38414GM-R10-1200	12	1.0	12	83	26	11.50	38	4		•	
5602R38414GM-R15-1200	12	1.5	12	83	26	11.50	38	4		•	
5602R38414GM-R20-1200	12	2.0	12	83	26	11.50	38	4		•	
5602R38414GM-R10-1600	16	1.0	16	92	32	15.50	44	4		•	
5602R38414GM-R15-1600	16	1.5	16	92	32	15.50	44	4		•	
5602R38414GM-R20-1600	16	2.0	16	92	32	15.50	44	4		•	
5602R38414GM-R30-1600	16	3.0	16	92	32	15.50	44	4		•	
5602R38414GM-R10-2000	20	1.0	20	104	38	19.50	54	4		•	
5602R38414GM-R15-2000	20	1.5	20	104	38	19.50	54	4		•	
5602R38414GM-R20-2000	20	2.0	20	104	38	19.50	54	4		•	
5602R38414GM-R30-2000	20	3.0	20	104	38	19.50	54	4		•	

Material Overview · Material Übersicht

✓ = Very suitable · Sehr empfohlen
✓ = Suitable · Empfohlen

KMG405

Workpiece material Werkstückstoff											
Carbon steel Kohlenstoff- Stahl	Alloy steel Legierter Stahl	Hardened steel Gehärteter Stahl				Stainless steel · Rostfreier Stahl	Cast iron, Nodular cast iron Grauguss GGG	Copper alloy Kupfer Leg.	Aluminum alloy Alu. Leg.	Titanium alloy Titan Leg.	Heat resist. alloy Warmfeste Leg.
		~40HRC	~50HRC	~60HRC	~68HRC						
✓	✓	✓	✓			✓	✓			✓	✓

VSM-4E for difficult to machine material with sharp cutting edge
VSM-4E für schwerzerspanbares Material, mit scharfer Schneide



4-flute end mills with straight shank and long cutting edge
 4-Schneiden Eckfräser mit langer Schneide und Zylinderschaft

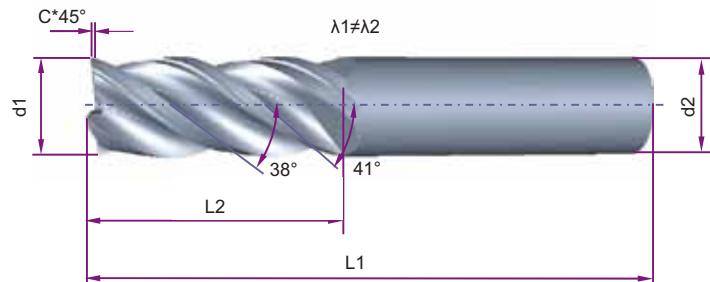
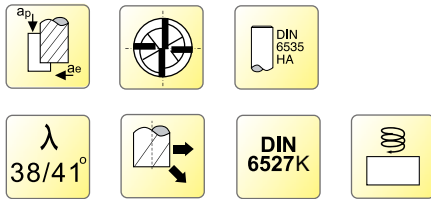

Type · Typ	Dimension(mm) Abmessungen					Teeth Zähne	Application Anwendung	P M S
	d1	d2	L2	L1	C*45°			
VSM-4E-D4.0	4	6	11	50	0.01-0.06	4		●
VSM-4E-D5.0	5	6	13	50	0.01-0.06	4		●
VSM-4E-D6.0	6	6	16	50	0.06-0.10	4		●
VSM-4E-D8.0	8	8	20	60	0.06-0.10	4		●
VSM-4E-D10.0	10	10	25	75	0.06-0.10	4		●
VSM-4E-D12.0	12	12	30	75	0.10-0.15	4		●
VSM-4E-D16.0	16	16	45	100	0.10-0.15	4		●
VSM-4E-D20.0	20	20	45	100	0.15-0.20	4		●

Material Overview · Material Übersicht

✓ = Very suitable · Sehr empfohlen
 ✓ = Suitable · Empfohlen

KMG405

		Workpiece material Werkstückstoff									
Carbon steel Kohlenstoff- Stahl	Alloy steel Legierter Stahl	Hardened steel Gehärteter Stahl				Stainless steel · Rostfreier Stahl	Cast iron, Nodular cast iron Grauguss GGG	Copper alloy Kupfer Leg.	Aluminum alloy Alu. Leg.	Titanium alloy Titan Leg.	Heat resist. alloy Warmfeste Leg.
		~40HRC	~50HRC	~60HRC	~68HRC						
✓	✓					✓				✓	✓

VSM-4R for difficult to machine material with radius
VSM-4R für schwerzerspanbares Material, mit Radius

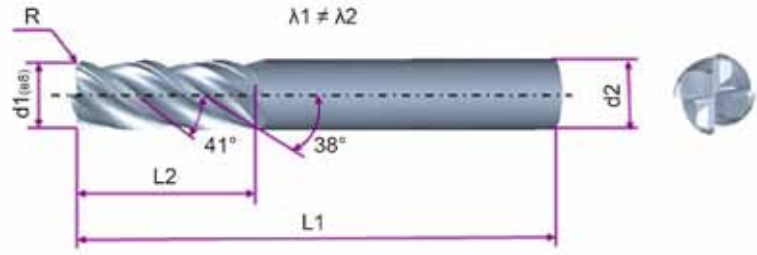
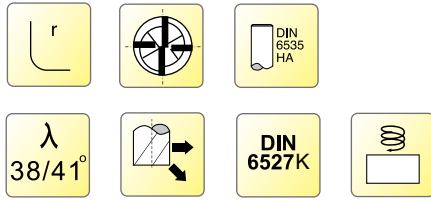

Type · Typ	Dimension(mm) Abmessungen					Teeth Zähne Z	Applicaion Anwendung Grade Sorte	P M S		
	d1(e8)	R±0.01	d2(h6)	L1	L2			KMG 405		
VSM-4R-D4.0R0.2	4	0.2	6	50	11	4				•
VSM-4R-D4.0R0.5	4	0.5	6	50	11	4				•
VSM-4R-D5.0R0.2	5	0.2	6	50	13	4				•
VSM-4R-D5.0R0.5	5	0.5	6	50	13	4				•
VSM-4R-D6.0R0.2	6	0.2	6	50	16	4				•
VSM-4R-D6.0R0.5	6	0.5	6	50	16	4				•
VSM-4R-D6.0R1.0	6	1.0	6	50	16	4				•
VSM-4R-D6.0R1.5	6	1.5	6	50	16	4				•
VSM-4R-D8.0R0.5	8	0.5	8	63	20	4				•
VSM-4R-D8.0R0.8	8	0.8	8	63	20	4				•
VSM-4R-D8.0R1.0	8	1.0	8	63	20	4				•
VSM-4R-D8.0R1.5	8	1.5	8	63	20	4				•
VSM-4R-D8.0R2.0	8	2.0	8	63	20	4				•
VSM-4R-D10.0R0.5	10	0.5	10	75	25	4				•
VSM-4R-D10.0R0.8	10	0.8	10	75	25	4				•
VSM-4R-D10.0R1.0	10	1.0	10	75	25	4				•
VSM-4R-D10.0R1.5	10	1.5	10	75	25	4				•
VSM-4R-D10.0R2.0	10	2.0	10	75	25	4				•
VSM-4R-D12.0R0.5	12	0.5	12	75	30	4				•
VSM-4R-D12.0R0.8	12	0.8	12	75	30	4				•
VSM-4R-D12.0R1.0	12	1.0	12	75	30	4				•
VSM-4R-D12.0R1.5	12	1.5	12	75	30	4				•
VSM-4R-D12.0R2.0	12	2.0	12	75	30	4				•
VSM-4R-D12.0R2.5	12	2.5	12	75	30	4				•
VSM-4R-D12.0R3.0	12	3.0	12	75	30	4				•
VSM-4R-D12.0R4.0	12	4.0	12	75	30	4				•
VSM-4R-D16.0R0.5	16	0.5	16	100	45	4				•
VSM-4R-D16.0R0.8	16	0.8	16	100	45	4				•
VSM-4R-D16.0R1.0	16	1.0	16	100	45	4				•
VSM-4R-D16.0R1.5	16	1.5	16	100	45	4				•
VSM-4R-D16.0R2.0	16	2.0	16	100	45	4				•
VSM-4R-D16.0R2.5	16	2.5	16	100	45	4				•
VSM-4R-D16.0R3.0	16	3.0	16	100	45	4				•
VSM-4R-D16.0R4.0	16	4.0	16	100	45	4				•
VSM-4R-D20.0R0.5	20	0.5	20	100	45	4				•
VSM-4R-D20.0R1.0	20	1.0	20	100	45	4				•
VSM-4R-D20.0R1.5	20	1.5	20	100	45	4				•
VSM-4R-D20.0R2.0	20	2.0	20	100	45	4				•
VSM-4R-D20.0R2.5	20	2.5	20	100	45	4				•
VSM-4R-D20.0R3.0	20	3.0	20	100	45	4				•
VSM-4R-D20.0R4.0	20	4.0	20	100	45	4				•

Material Overview · Material Übersicht

KMG405

		Workpiece material Werkstückstoff									
Carbon steel Kohlenstoff- Stahl	Alloy steel Legierter Stahl	Hardened steel Gehärteter Stahl				Stainless steel · Rostfreier Stahl	Cast iron, Nodular cast iron Grauguss GG	Copper alloy Kupfer Leg.	Aluminum alloy Alu. Leg.	Titanium alloy Titan Leg.	Heat resist. alloy Warmfeste Leg.
		~40HRC	~50HRC	~60HRC	~68HRC						
✓	✓					✓				✓	✓

Vibration Test / Vibrationsuntersuchung

Diameter / Durchmesser Ømm	Material	V _c m/min	f _z mm/z	a _p mm	a _e mm
6	1Cr18Ni9Ti	80	0,05	9	0,3



- Surface quality of the contour with the conventional end mills
- Oberflächengüte der Kontur mit herkömmlichem VHM-Fräser



- Surface quality of the contour with the ZCCCT HPC end mill
- Oberflächengüte der Kontur mit HPC VHM-Fräser von ZCCCT

Tool Life / Standzeit (Machining time / Bearbeitungszeit: 180min.)

Diameter / Durchmesser Ømm	Material	V _c m/min	f _z mm/z	a _p mm	a _e mm
8	42CrMo HRC35	160	0,04	12	1,2



Company A
HPC35°/38°
V_{bmax} = 0,117mm



ZCCCT
HPC 38°/41°
V_{bmax}=0.072mm

Roughing / Schruppen



Workpiece	Werkstück	alloy steel leg. Stahl	alloy steel leg. Stahl	Ferritic stainless steel rostfreier Stahl	Ferritic stainless steel rostfreier Stahl
Material	Werkstoff	1.2714 steel	1.2714 steel	1.4313 X5CrNi134	1.4301 X5CrNi189
Hardness Tensile Strength	Härte Zugfestigkeit N/mm ²	1400	1400		
Cutting tools	Werkzeug				
Teeth Z	Zähnezahl Z	4	4	4	4
Producer/Supplier	Hersteller (Werkzeug)	ZCCCT	ZCCCT	ZCCCT	ZCCCT
Grade	Schneidstoff Sorte	KMG405	KMG405	KMG405	KMG405
Solid carbide tools art no.	Vollhartmetallwerkzeug Nr.	D8, λ=38/41	D12, λ=38/41	D12, λ=38/41	D12, λ=38/41
Cutting condition	Schnittdaten				
RPM n=r/min	Drehzahl n=U/min	5971	3980	4775	4775
Cutting speed Vc=m/min	Schnittgeschw. Vc=m/min	150	150	180	180
Feed rate f=mm/r	Vorschub f=mm/U	fz=0.05	fz=0.075	0.15	0.15
Depth of cut ap mm	Schnitttiefe ap mm	8	12	25	25
Depth of cut ae mm	Schnittbreite ae mm	3,6	5,4	1,5	1,5



HPC Endmills
HPC Fräser

ZCC-ET

Sales center in Europe
Vertriebszentrale in Europa:

ZCC Cutting Tools Europe GmbH

www.zccct-europe.com www.zccct.com

Heltorfer Straße 12 40472 Düsseldorf

Tel.: +49(0)211-989240-0

Fax: +49(0)211-989240-111

E-mail: Info@zccct-europe.com

Distributor
Vertretung