



Clarkson GmbH



HSK-A

04/2017



Werkzeugaufnahme HSK Toolholders HSK

DIN 69893-HSK Form A

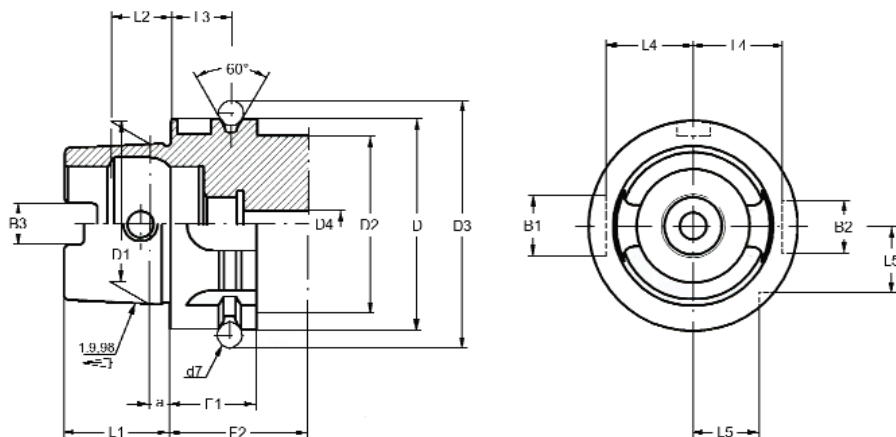

HSK	D h10	D1	D2 max.	D3 ^{-0,1}	B1 H10	B2 H10	B3 ^{+0,04}	d7	D4 max.	L1 ^{-0,2}	L2 JS10	L3 ^{+0,1}	L5 ^{-0,3}	F1 ^{-0,1}	F2 min.	a
25	25	19	20	25,8	7	6	6,05	3	3	13	7,21	4,5	10	10	20	2,5
32	32	24	26	37	9	7	7,05	4	4,2	16	8,92	16	13	20	35	3,2
40	40	30	34	45	11	9	8,05	4	5	20	11,42	16	17	20	35	4
50	50	38	42	59,3	14	12	10,54	7	6,8	25	14,13	18	21	26	42	5
63	63	48	53	72,3	18	16	12,54	7	8,4	32	18,13	18	26,5	26	42	6,3
80	80	60	68	88,8	20	18	16,04	7	10,2	40	22,85	18	34	26	42	8
100	100	75	88	109,75	22	20	20,02	7	12	50	28,56	20	44	29	45	10
125	125	95	111	134,75	28	25	25,02	7	14	63	36,27	20	55,5	29	45	12,5

Werkstoff:

Hochlegierter Einsatzstahl

Zugfestigkeit im Kern:min 1200 N/mm²

Einsatzgehärtet HRC 60 ± 2 (HV 700 ± 50)

Härtetiefe 0,8mm ± 0,2mm

Genauigkeit:

Kegelwinkel-Toleranzqualität < AT 3 nach DIN7187

Material:

High alloyed case-hardened steel

Tensile core strength:of min. 1200 N/mm²

Case hardened HRC 60 ± 2 (HV 700 ± 50)

Hardening depth 0,8mm ± 0,2mm

Accuracy:

quality of taper < AT 3 according to DIN7187



Inhaltsverzeichnis

255	Seite/page :A04	227	Seite/page :A18	898	Seite/page :A36	231	Seite/page :C08
241	Seite/page :A05	342	Seite/page :A19	253	Seite/page :B01-04	456-484	Seite/page :C09
242	Seite/page :A06	340	Seite/page :A20	286	Seite/page :B05	458-457	Seite/page :C10
250	Seite/page :A07	350	Seite/page :A21	288	Seite/page :B05	331	Seite/page :C11
269	Seite/page :A08/09	271	Seite/page :A22-24	283	Seite/page :B06/07	334	Seite/page :C12
279	Seite/page :A10	272	Seite/page :A25	267	Seite/page :B08	K...	Seite/page :C13
268	Seite/page :A11	273	Seite/page :A26	257	Seite/page :B09	S...	Seite/page :C13
220	Seite/page :A12	280	Seite/page :A27-30	258	Seite/page :B09		Seite/page :C13-16
						Ersatzteile Spar-parts	
221	Seite/page :A13	281	Seite/page :A31	276	Seite/page :B10		
238	Seite/page :A14	282	Seite/page :A32	435	Seite/page :C01		
240	Seite/page :A15/16	260	Seite/page :A33-35	228	Seite/page :C02-06		
254	Seite/page :A17	361	Seite/page :A36	229	Seite/page :C07		



Zangenfutter DIN 6391 für Spannzangen DIN 6388-B

HSK-A

Collet chucks DIN 6391 for Collets DIN 6388-B

HSK-A

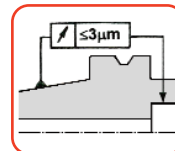
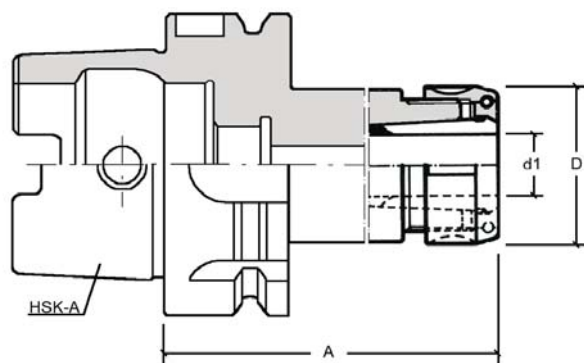

Bestell Nr. Code No.	HSK	Zange Collet OZ	Spannbereich Capacity d1	A mm	D mm
255.A50.016.100	50	OZ16	2-16	100	43
255.A50.025.100	50	OZ25	2-25	100	60
255.A63.016.100	63	OZ16	2-16	100	43
255.A63.025.100	63	OZ25	2-25	100	60
255.A63.032.120	63	OZ32	4-32	120	72
255.A10.016.110	100	OZ16	2-16	110	43
255.A10.025.120	100	OZ25	2-25	120	60
255.A10.032.130	100	OZ32	4-32	130	72



C09-10



C16



C01



C13



C13

Lieferumfang:
Mit kugelgelagerter Spannmutter
Delivery:
With ball bearing clamping nut



Zangenfutter für ER-Spannzangen DIN 6499

HSK-A

Collet chucks for ER-Collets to DIN 6499

HSK-A

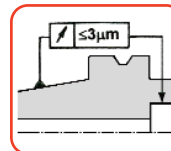
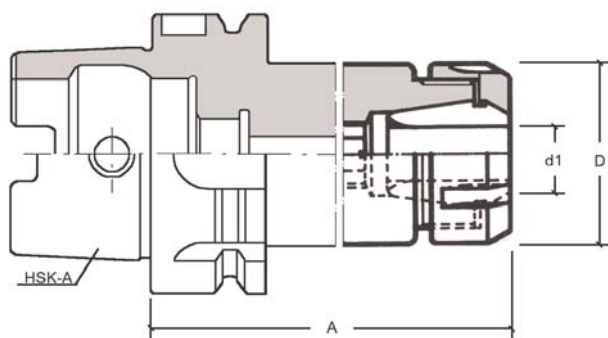

Bestell Nr. Code No.	HSK	Zange Collet ER	Spannbereich Capacity d1	A mm	D mm
241.A32.016.080	32	ER16	1-10	80	28
241.A32.025.080	32	ER25	2-16	80	42
241.A40.016.080	40	ER16	1-10	80	28
241.A40.025.080	40	ER25	2-16	80	42
241.A40.032.100	40	ER32	2-20	100	50
241.A50.016.100	50	ER16	1-10	100	28
241.A50.025.100	50	ER25	2-16	100	42
241.A50.032.100	50	ER32	2-20	100	50
241.A63.016.075	63	ER16	1-10	75	32
241.A63.016.100	63	ER16	1-10	100	28
241.A63.016.130	63	ER16	1-10	130	28
241.A63.016.160	63	ER16	1-10	160	28
241.A63.025.075	63	ER25	2-16	75	42
241.A63.025.100	63	ER25	2-16	100	42
241.A63.025.130	63	ER25	2-16	130	42
241.A63.025.160	63	ER25	2-16	160	42
241.A63.032.075	63	ER32	2-20	75	50
241.A63.032.100	63	ER32	2-20	100	50
241.A63.032.130	63	ER32	2-20	130	50
241.A63.032.160	63	ER32	2-20	160	50
241.A63.040.090	63	ER40	3-26	90	63
241.A63.040.120	63	ER40	3-26	120	63
241.A63.040.130	63	ER40	3-26	130	63
241.A63.040.160	63	ER40	3-26	160	63

Bestell Nr. Code No.	HSK	Zange Collet ER	Spannbereich Capacity d1	A mm	D mm
241.A80.032.100	80	ER32	2-20	100	50
241.A80.040.120	80	ER40	3-26	120	63
241.A10.016.100	100	ER16	1-10	100	32
241.A10.016.160	100	ER16	1-10	160	32
241.A10.025.100	100	ER25	2-16	100	42
241.A10.025.160	100	ER25	2-16	160	42
241.A10.032.100	100	ER32	2-20	100	50
241.A10.032.160	100	ER32	2-20	160	50
241.A10.040.100	100	ER40	3-26	100	63
241.A10.040.120	100	ER40	3-26	120	63
241.A10.040.160	100	ER40	3-26	160	63

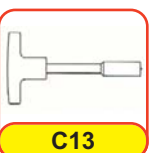

Lieferumfang:
Mit gewuchteter Spannmutter
Delivery:
With balanced clamping nut



Mini-Zangenfutter für ER-Spannzangen DIN 6499

HSK-A

Mini-Collet chucks for ER-Collets to DIN 6499

HSK-A

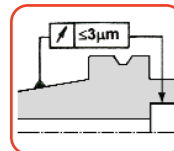
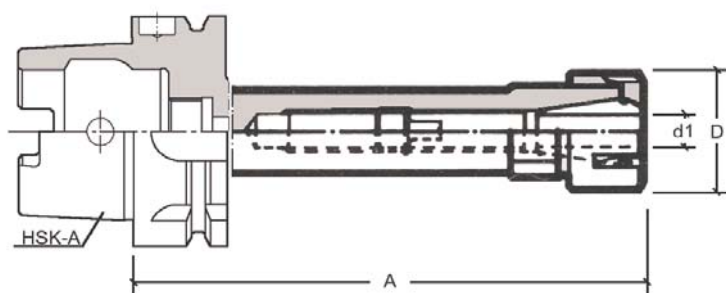

Bestell Nr. Code No.	HSK	Zange Collet ER	Spannbereich Capacity d1	A mm	D mm
242.A63.011.100	63	ER11	1-7	100	16
242.A63.011.130	63	ER11	1-7	130	16
242.A63.011.160	63	ER11	1-7	160	16
242.A63.016.100	63	ER16	1-10	100	22
242.A63.016.130	63	ER16	1-10	130	22
242.A63.016.160	63	ER16	1-10	160	22
242.A63.025.100	63	ER25	2-16	100	35
242.A63.025.160	63	ER25	2-16	160	35





Präzisions-Zangenkraftspannfutter

HSK-A

Precision Great Power Collet chuck

HSK-A

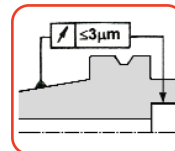
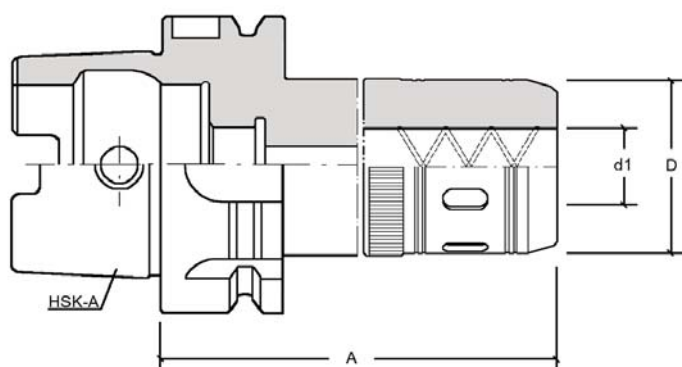

Bestell Nr. Code No.	HSK	Spannbereich Capacity d1	A mm	D mm
250.A40.016.080	40	16	80	40
250.A40.016.100	40	16	100	40
250.A50.016.075	50	16	75	40
250.A50.016.100	50	16	100	40
250.A50.020.100	50	20	100	50
250.A63.016.075	63	16	75	40
250.A63.016.100	63	16	100	40
250.A63.016.135	63	16	135	40
250.A63.020.085	63	20	85	46
250.A63.A20.085	63	20	85	50
250.A63.020.110	63	20	110	46
250.A63.A20.110	63	20	110	50
250.A63.020.135	63	20	135	50
250.A63.025.105	63	25	105	62
250.A63.025.130	63	25	130	62
250.A63.032.110	63	32	110	62
250.A63.032.130	63	32	130	62
250.A80.020.095	80	20	95	46
250.A80.A20.095	80	20	95	50
250.A80.032.110	80	32	110	62
250.A10.020.105	100	20	105	46
250.A10.A20.105	100	20	105	50
250.A10.020.135	100	20	135	50
250.A10.032.115	100	32	115	62
250.A10.032.135	100	32	135	62
250.A10.040.125	100	40	125	85
250.A10.050.135	100	50	135	99

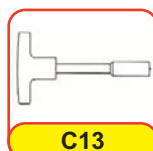



Fräsfutter DIN 6359 für Zylinderschäfte DIN1835B

HSK-A

Weldon chucks DIN 6359 for shanks to DIN1835B

HSK-A

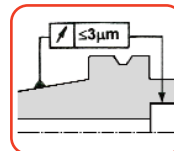
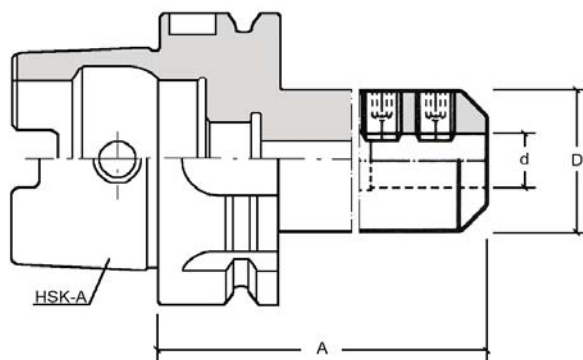

Bestell Nr. Code No.	HSK	Spannbereich Capacity d	A mm	D mm
269.A32.006.060	32	6	60	25
269.A32.008.060	32	8	60	28
269.A32.010.065	32	10	65	35
269.A32.012.065	32	12	65	42
269.A40.006.060	40	6	60	25
269.A40.008.060	40	8	60	28
269.A40.010.060	40	10	60	35
269.A40.012.070	40	12	70	42
269.A40.016.075	40	16	75	48
269.A50.006.065	50	6	65	25
269.A50.008.065	50	8	65	28
269.A50.010.065	50	10	65	35
269.A50.012.080	50	12	80	42
269.A50.014.080	50	14	80	44
269.A50.016.080	50	16	80	48
269.A50.018.080	50	18	80	50
269.A50.020.080	50	20	80	52
269.A63.006.065	63	6	65	25
269.A63.006.100	63	6	100	25
269.A63.006.120	63	6	120	25
269.A63.006.130	63	6	130	25
269.A63.006.160	63	6	160	25
269.A63.008.065	63	8	65	28
269.A63.008.100	63	8	100	28
269.A63.008.120	63	8	120	28
269.A63.008.130	63	8	130	28
269.A63.008.160	63	8	160	28
269.A63.010.065	63	10	65	35
269.A63.010.100	63	10	100	35
269.A63.010.120	63	10	120	35
269.A63.010.130	63	10	130	35
269.A63.010.160	63	10	160	35
269.A63.012.080	63	12	80	42
269.A63.012.120	63	12	120	42

Bestell Nr. Code No.	HSK	Spannbereich Capacity d	A mm	D mm
269.A63.012.130	63	12	130	42
269.A63.012.160	63	12	160	42
269.A63.014.080	63	14	80	44
269.A63.014.120	63	14	120	44
269.A63.014.130	63	14	130	44
269.A63.014.160	63	14	160	44
269.A63.016.080	63	16	80	48
269.A63.016.120	63	16	120	48
269.A63.016.130	63	16	130	48
269.A63.016.160	63	16	160	48
269.A63.018.080	63	18	80	50
269.A63.018.120	63	18	120	50
269.A63.018.130	63	18	130	50
269.A63.018.160	63	18	160	50
269.A63.020.080	63	20	80	52
269.A63.020.120	63	20	120	52
269.A63.020.130	63	20	130	52
269.A63.020.160	63	20	160	52
269.A63.025.110	63	25	110	65
269.A63.025.160	63	25	160	65
269.A63.032.110	63	32	110	72
269.A63.032.160	63	32	160	72
269.A63.040.120	63	40	120	80
269.A63.040.125	63	40	125	80
269.A80.006.080	80	6	80	25
269.A80.008.080	80	8	80	28
269.A80.010.080	80	10	80	35
269.A80.012.080	80	12	80	42
269.A80.014.080	80	14	80	44
269.A80.016.100	80	16	100	48
269.A80.018.100	80	18	100	50
269.A80.020.100	80	20	100	52
269.A80.025.100	80	25	100	63
269.A80.032.110	80	32	110	72



Hinweis:
Ab \varnothing d 25mm mit 2 Spannschrauben
Note:
From \varnothing d 25mm with 2 clamping screws

Lieferumfang:
Mit Spannschraube(n)
Delivery:
With clamping screw(s)



Fräsfutter DIN 6359 für Zylinderschäfte DIN1835B

HSK-A

Weldon chucks DIN 6359 for shanks to DIN1835B

HSK-A

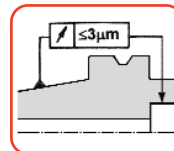
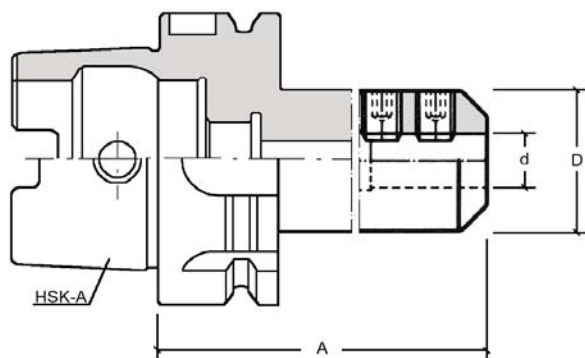

Bestell Nr. Code No.	HSK	Spannbereich Capacity d	A mm	D mm
269.A10.006.080	100	6	80	25
269.A10.006.120	100	6	120	25
269.A10.006.130	100	6	130	25
269.A10.006.160	100	6	160	25
269.A10.008.080	100	8	80	28
269.A10.008.120	100	8	120	28
269.A10.008.130	100	8	130	28
269.A10.008.160	100	8	160	28
269.A10.010.080	100	10	80	35
269.A10.010.120	100	10	120	35
269.A10.010.130	100	10	130	35
269.A10.010.160	100	10	160	35
269.A10.012.080	100	12	80	42
269.A10.012.120	100	12	120	42
269.A10.012.130	100	12	130	42
269.A10.012.160	100	12	160	42
269.A10.014.080	100	14	80	44
269.A10.014.120	100	14	120	44
269.A10.014.130	100	14	130	44
269.A10.014.160	100	14	160	44
269.A10.016.100	100	16	100	48

Bestell Nr. Code No.	HSK	Spannbereich Capacity d	A mm	D mm
269.A10.016.120	100	16	120	48
269.A10.016.130	100	16	130	48
269.A10.016.160	100	16	160	48
269.A10.018.100	100	18	100	50
269.A10.018.120	100	18	120	50
269.A10.018.130	100	18	130	50
269.A10.018.160	100	18	160	50
269.A10.020.100	100	20	100	52
269.A10.020.120	100	20	120	52
269.A10.020.130	100	20	130	52
269.A10.020.160	100	20	160	52
269.A10.025.100	100	25	100	65
269.A10.025.130	100	25	130	63
269.A10.025.160	100	25	160	65
269.A10.032.100	100	32	100	72
269.A10.032.130	100	32	130	72
269.A10.032.160	100	32	160	72
269.A10.040.105	100	40	105	80
269.A10.040.110	100	40	110	80
269.A10.040.130	100	40	130	80
269.A10.040.160	100	40	160	80



C14



C13

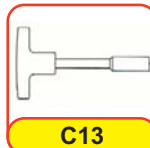

C13

Hinweis:
Ab $\varnothing d$ 25mm mit 2 Spannschrauben
Note:
From $\varnothing d$ 25mm with 2 clamping screws

Lieferumfang:
Mit Spannschraube(n)
Delivery:
With clamping screw(s)



Fräsfutter DIN 6359 für Zylinderschäfte DIN1835B

HSK-A

Weldon chucks DIN 6359 for shanks to DIN1835B

HSK-A

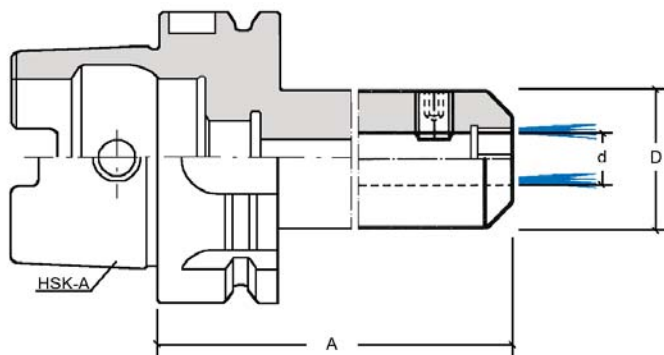

für HSK100

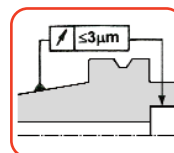

Bestell Nr. Code No.	HSK	Spannbereich Capacity d	A mm	D mm
279.A32.006.060	32	6	60	25
279.A32.008.060	32	8	60	28
279.A32.010.065	32	10	65	35
279.A32.012.065	32	12	65	42
279.A40.006.060	40	6	60	25
279.A40.008.060	40	8	60	28
279.A40.010.060	40	10	60	35
279.A40.012.070	40	12	70	42
279.A40.016.075	40	16	75	48
279.A50.006.065	50	6	65	25
279.A50.008.065	50	8	65	28
279.A50.010.065	50	10	65	35
279.A50.012.080	50	12	80	42
279.A50.014.080	50	14	80	44
279.A50.016.080	50	16	80	48
279.A50.018.080	50	18	80	50
279.A50.020.080	50	20	80	52
279.A63.006.065	63	6	65	25
279.A63.008.065	63	8	65	28
279.A63.010.065	63	10	65	35
279.A63.012.080	63	12	80	42
279.A63.014.080	63	14	80	44
279.A63.016.080	63	16	80	48
279.A63.018.080	63	18	80	50
279.A63.020.080	63	20	80	62
279.A63.025.110	63	25	110	63
279.A63.032.110	63	32	110	72
279.A63.040.125	63	40	125	80

Bestell Nr. Code No.	HSK	Spannbereich Capacity d	A mm	D mm
279.A80.006.080	80	6	80	25
279.A80.008.080	80	8	80	28
279.A80.010.080	80	10	80	35
279.A80.012.080	80	12	80	42
279.A80.014.080	80	14	80	44
279.A80.016.100	80	16	100	48
279.A80.018.100	80	18	100	50
279.A80.020.100	80	20	100	52
279.A80.025.100	80	25	100	65
279.A80.032.110	80	32	110	72
279.A10.006.080	100	6	80	25
279.A10.008.080	100	8	80	28
279.A10.010.080	100	10	80	35
279.A10.012.080	100	12	80	42
279.A10.014.080	100	14	80	42
279.A10.016.100	100	16	100	48
279.A10.018.100	100	18	100	48
279.A10.020.100	100	20	100	52
279.A10.025.100	100	25	100	65
279.A10.032.100	100	32	100	72
279.A10.040.105	100	40	105	80



C14



C13



C13

Hinweis:
Ab \varnothing 25mm mit 2 Spannschrauben
von \varnothing 6 bis 14mm mit 2 Kühlkanälen
von \varnothing 16 bis 40mm mit 4 Kühlkanälen
Für Werkzeuge mit IK ist ein O-Ring erforderlich

Lieferumfang:
Mit Spannschraube(n) und O-Ring
Delivery:
With clamping screw(s) and O-ring



Fräsfutter DIN 6359 Whistle Notch für Zylinderschäfte DIN1835E

HSK-A

Whistle Notch chucks DIN 6359 for shanks to DIN1835E

HSK-A

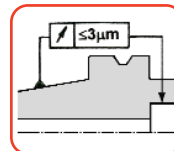
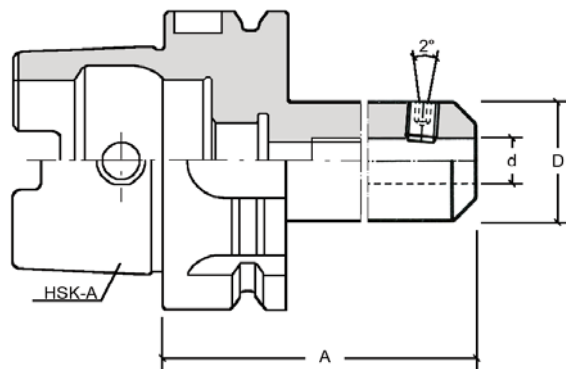

Bestell Nr. Code No.	HSK	Spannbereich Capacity d	A mm	D mm
268.A32.006.080	32	6	80	25
268.A32.008.080	32	8	80	28
268.A32.010.080	32	10	80	35
268.A40.006.080	40	6	80	25
268.A40.008.080	40	8	80	28
268.A40.010.080	40	10	80	35
268.A40.012.090	40	12	90	42
268.A40.014.090	40	14	90	44
268.A40.016.090	40	16	90	48
268.A50.006.080	50	6	80	25
268.A50.008.080	50	8	80	28
268.A50.010.080	50	10	80	35
268.A50.012.090	50	12	90	42
268.A50.014.090	50	14	90	44
268.A50.016.090	50	16	90	48
268.A50.018.090	50	18	90	50
268.A50.020.100	50	20	100	52
268.A63.006.080	63	6	80	25
268.A63.008.080	63	8	80	28
268.A63.010.080	63	10	80	35
268.A63.012.090	63	12	90	42
268.A63.014.090	63	14	90	44
268.A63.016.100	63	16	100	48
268.A63.018.100	63	18	100	50
268.A63.020.100	63	20	100	52
268.A63.025.110	63	25	110	63
268.A63.032.110	63	32	110	72

Bestell Nr. Code No.	HSK	Spannbereich Capacity d	A mm	D mm
268.A80.006.090	80	6	90	25
268.A80.008.090	80	8	90	28
268.A80.010.090	80	10	90	35
268.A80.012.100	80	12	100	42
268.A80.014.100	80	14	100	44
268.A80.016.100	80	16	100	48
268.A80.018.100	80	18	100	50
268.A80.020.110	80	20	110	52
268.A80.025.110	80	25	110	65
268.A80.032.120	80	32	120	72
268.A10.006.090	100	6	90	25
268.A10.008.090	100	8	90	28
268.A10.010.090	100	10	90	35
268.A10.012.100	100	12	100	42
268.A10.014.100	100	14	100	44
268.A10.016.100	100	16	100	48
268.A10.018.100	100	18	100	50
268.A10.020.110	100	20	110	52
268.A10.025.120	100	25	120	65
268.A10.032.120	100	32	120	72
268.A10.040.120	100	40	120	80

Hinweis:
Ab $\varnothing d$ 25mm mit 2 Spannschrauben
Note:
From $\varnothing d$ 25mm with 2 clamping screws

Lieferumfang:
Mit Spannschraube(n) und axialer Anschlagschraube
Delivery:
With clamping screw(s) and stopscrew





Zwischenhülse für MK mit Austreibblappen DIN 6383

HSK-A

Morse taper adaptor for MT with tang DIN 6383

HSK-A

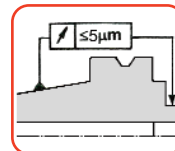
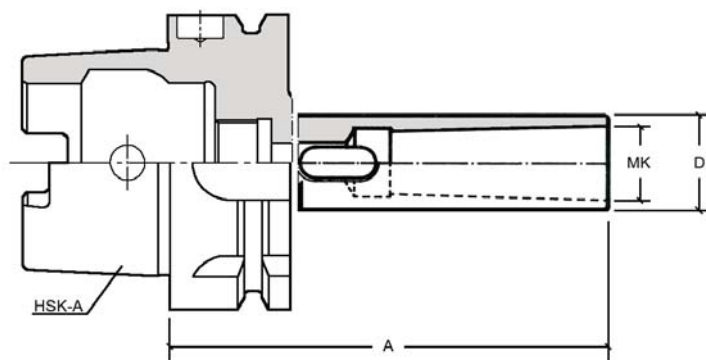

Bestell Nr. Code No.	HSK	Morse Kegel Morse Taper MK	A mm	D mm
220.A50.001.100	50	1	100	25
220.A50.002.120	50	2	120	32
220.A50.003.140	50	3	140	40
220.A63.001.100	63	1	100	25
220.A63.002.120	63	2	120	32
220.A63.003.140	63	3	140	40
220.A63.004.160	63	4	160	48
220.A80.001.110	80	1	110	25
220.A80.002.120	80	2	120	32
220.A80.003.150	80	3	150	40
220.A80.004.170	80	4	170	48
220.A10.001.110	100	1	110	25
220.A10.002.120	100	2	120	32
220.A10.003.150	100	3	150	40
220.A10.004.170	100	4	170	48
220.A10.005.200	100	5	200	63

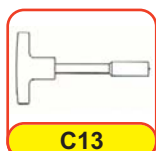



Zwischenhülse für MK mit Anzugsgewinde DIN 6364

HSK-A

Morse taper adaptor for MT with tang DIN 6364

HSK-A

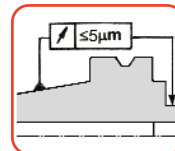
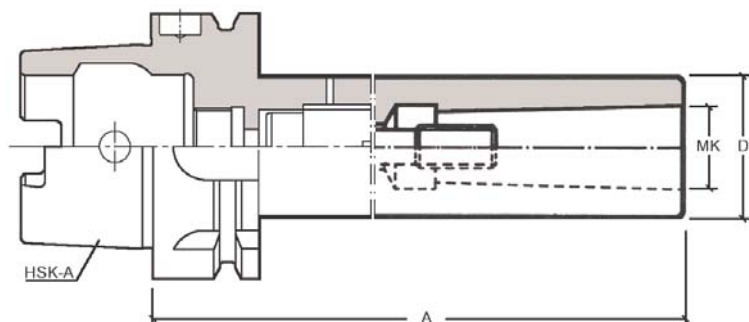

Bestell Nr. Code No.	HSK	Morse Kegel Morse Taper MK	A mm	D mm
221.A50.001.100	50	1	100	25
221.A50.002.120	50	2	120	32
221.A50.003.140	50	3	140	40
221.A63.001.100	63	1	100	25
221.A63.002.120	63	2	120	32
221.A63.003.140	63	3	140	40
221.A63.004.160	63	4	160	48
221.A80.001.110	80	1	110	25
221.A80.002.120	80	2	120	32
221.A80.003.150	80	3	150	40
221.A80.004.170	80	4	170	48
221.A10.001.110	100	1	110	25
221.A10.002.120	100	2	120	32
221.A10.003.150	100	3	150	40
221.A10.004.170	100	4	170	48
221.A10.005.200	100	5	200	63



C13

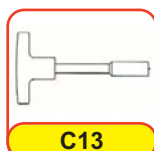

C13

Lieferumfang:
Mit Fräseranzugsschraube
Delivery:
With tightening bold



Kombi-Aufsteckfräserdorne DIN 6358

HSK-A

Combi shell mill holders DIN 6358

HSK-A

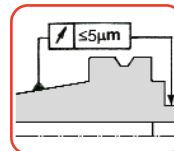
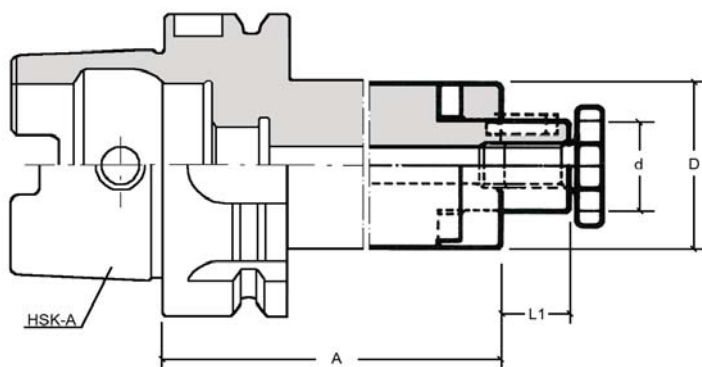

Bestell Nr. Code No.	HSK	d mm	L1 mm	A mm	D mm
238.A32.016.055	32	16	17	55	32
238.A32.022.055	32	22	19	55	40
238.A32.027.065	32	27	21	65	48
238.A40.016.050	40	16	17	50	32
238.A40.022.050	40	22	19	50	40
238.A40.027.065	40	27	21	65	48
238.A50.016.050	50	16	17	50	32
238.A50.022.050	50	22	19	50	40
238.A50.027.065	50	27	21	65	48
238.A50.032.065	50	32	24	65	58
238.A63.016.060	63	16	17	60	32
238.A63.016.100	63	16	17	100	32
238.A63.016.130	63	16	17	130	32
238.A63.016.160	63	16	17	160	32
238.A63.016.200	63	16	17	200	32
238.A63.022.060	63	22	19	60	40
238.A63.022.100	63	22	19	100	40
238.A63.022.130	63	22	19	130	40
238.A63.022.160	63	22	19	160	40
238.A63.022.200	63	22	19	200	40
238.A63.027.060	63	27	21	60	48
238.A63.027.100	63	27	21	100	48
238.A63.027.130	63	27	21	130	48
238.A63.027.160	63	27	21	160	48
238.A63.027.200	63	27	21	200	48
238.A63.032.060	63	32	24	60	58
238.A63.032.100	63	32	24	100	58
238.A63.032.130	63	32	24	130	58
238.A63.032.160	63	32	24	160	58
238.A63.040.070	63	40	27	70	70
238.A63.040.100	63	40	27	100	70
238.A63.040.130	63	40	27	130	70
238.A63.040.160	63	40	27	160	70

Bestell Nr. Code No.	HSK	d mm	L1 mm	A mm	D mm
238.A80.016.060	80	16	17	60	32
238.A80.022.060	80	22	19	60	40
238.A80.027.060	80	27	21	60	48
238.A80.032.060	80	32	24	60	58
238.A80.040.070	80	40	27	70	70
238.A10.016.060	100	16	17	60	32
238.A10.016.100	100	16	17	100	32
238.A10.016.130	100	16	17	130	32
238.A10.016.160	100	16	17	160	32
238.A10.016.200	100	16	17	200	32
238.A10.022.060	100	22	19	60	40
238.A10.022.100	100	22	19	100	40
238.A10.022.130	100	22	19	130	40
238.A10.022.160	100	22	19	160	40
238.A10.022.200	100	22	19	200	40
238.A10.027.060	100	27	21	60	48
238.A10.027.100	100	27	21	100	48
238.A10.027.130	100	27	21	130	48
238.A10.027.160	100	27	21	160	48
238.A10.027.200	100	27	21	200	48
238.A10.032.060	100	32	24	60	58
238.A10.032.100	100	32	24	100	58
238.A10.032.130	100	32	24	130	58
238.A10.032.160	100	32	24	160	58
238.A10.040.070	100	40	27	70	70
238.A10.040.100	100	40	27	100	70
238.A10.040.130	100	40	27	130	70
238.A10.040.160	100	40	27	160	70

Lieferumfang:
Mit Fräseranzugsschraube, Mitnehmerring und Passfeder
Delivery:
With retaining screw, driving ring and feather key

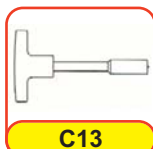



Quernut-Aufsteckfräserdorne DIN 6357 mit vergrößertem Bunddurchmesser

HSK-A

Shell mill holders DIN 6357 with enlarged contact face

HSK-A

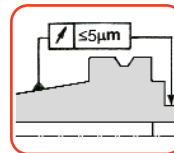
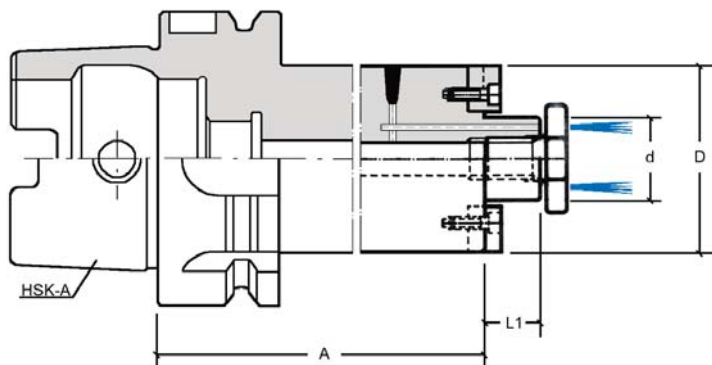

Bestell Nr. Code No.	HSK	d mm	L1 mm	A mm	D mm
240.A50.016.050	50	16	17	50	38
240.A50.022.060	50	22	19	60	48
240.A50.027.060	50	27	21	60	58
240.A50.032.060	50	32	24	60	78
240.A63.016.050	63	16	17	50	38
240.A63.016.100	63	16	17	100	38
240.A63.016.130	63	16	17	130	38
240.A63.016.160	63	16	17	160	38
240.A63.022.050	63	22	19	50	48
240.A63.022.100	63	22	19	100	48
240.A63.022.130	63	22	19	130	48
240.A63.022.160	63	22	19	160	48
240.A63.027.060	63	27	21	60	60
240.A63.027.100	63	27	21	100	60
240.A63.027.130	63	27	21	130	58
240.A63.027.160	63	27	21	160	60
240.A63.032.060	63	32	24	60	78
240.A63.032.100	63	32	24	100	78
240.A63.032.130	63	32	24	130	78
240.A63.032.160	63	32	24	160	78
240.A63.040.060	63	40	27	60	89
240.A63.040.100	63	40	27	100	89
240.A63.040.130	63	40	27	130	88
240.A63.040.160	63	40	27	160	89

Bestell Nr. Code No.	HSK	d mm	L1 mm	A mm	D mm
240.A80.022.050	80	22	19	50	48
240.A80.022.100	80	22	19	100	48
240.A80.022.130	80	22	19	130	48
240.A80.022.160	80	22	19	160	48
240.A80.027.050	80	27	21	50	58
240.A80.027.100	80	27	21	100	58
240.A80.027.130	80	27	21	130	58
240.A80.027.160	80	27	21	160	58
240.A80.032.060	80	32	24	60	78
240.A80.032.100	80	32	24	100	78
240.A80.032.130	80	32	24	130	78
240.A80.032.160	80	32	24	160	78
240.A80.040.060	80	40	27	60	88
240.A80.040.100	80	40	27	100	88
240.A80.040.130	80	40	27	130	88

Lieferumfang:
Mit Mitnehmersteinen, Kreuzschraube und Schraube DIN912
Delivery:
With drivers, cross head retaining screw and screw DIN912

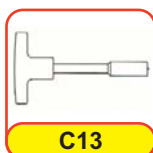
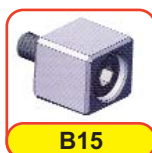



Quernut-Aufsteckfräserdorne DIN 6357 mit vergrößertem Bunddurchmesser

HSK-A

Shell mill holders DIN 6357 with enlarged contact face

HSK-A

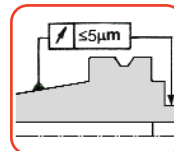
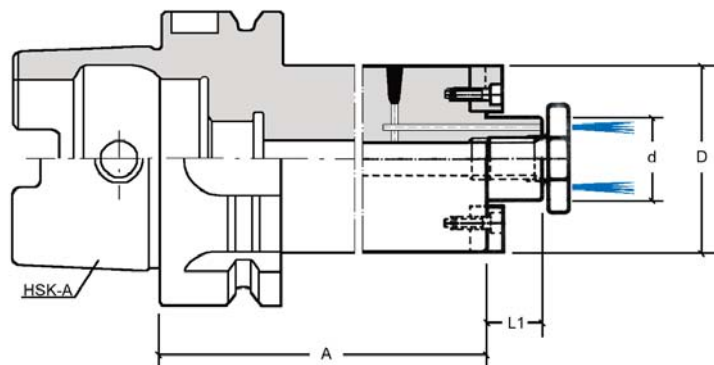

Bestell Nr. Code No.	HSK	d mm	L1 mm	A mm	D mm
240.A10.016.045	100	16	17	45	38
240.A10.016.050	100	16	17	50	38
240.A10.016.100	100	16	17	100	38
240.A10.016.130	100	16	17	130	38
240.A10.016.160	100	16	17	160	38
240.A10.016.200	100	16	17	200	38
240.A10.022.050	100	22	19	50	48
240.A10.022.100	100	22	19	100	48
240.A10.022.130	100	22	19	130	48
240.A10.022.160	100	22	19	160	48
240.A10.022.200	100	22	19	200	48
240.A10.027.050	100	27	21	50	60
240.A10.027.100	100	27	21	100	60
240.A10.027.130	100	27	21	130	58
240.A10.027.160	100	27	21	160	60

Bestell Nr. Code No.	HSK	d mm	L1 mm	A mm	D mm
240.A10.027.200	100	27	21	200	58
240.A10.032.050	100	32	24	50	78
240.A10.032.060	100	32	24	60	78
240.A10.032.100	100	32	24	100	78
240.A10.032.130	100	32	24	130	78
240.A10.032.160	100	32	24	160	78
240.A10.032.200	100	32	24	200	78
240.A10.040.060	100	40	27	60	88
240.A10.040.100	100	40	27	100	88
240.A10.040.130	100	40	27	130	88
240.A10.040.160	100	40	27	160	88
240.A10.060.070	100	60	40	70	128
240.A10.060.100	100	60	40	100	128
240.A10.060.130	100	60	40	130	128
240.A10.060.160	100	60	40	160	128

Lieferumfang:
Mit Mitnehmersteinen, Kreuzschraube und Schraube DIN912
Delivery:
With drivers, cross head retaining screw and screw DIN912

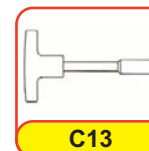



Fräseraufnahme für Einschraubfräser

Milling abors for screw in tool

HSK-A

HSK-A

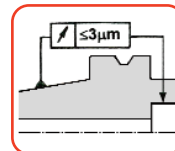
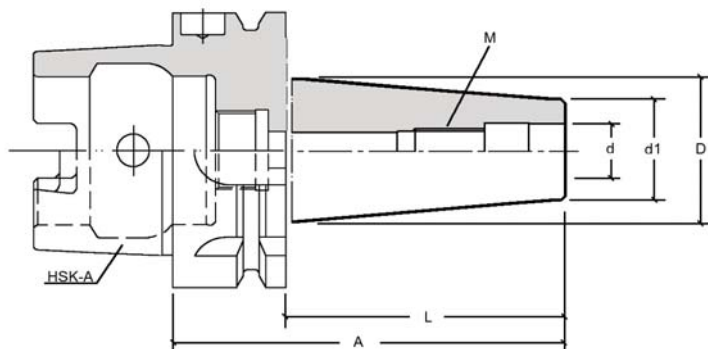

Bestell Nr. Code No.	HSK	M	d mm	d1 mm	D mm	A mm	L mm
-------------------------	-----	---	---------	----------	---------	---------	---------

254.A63.M06.051	63	6	6,5	10	11,5	51	25
254.A63.M06.076	63	6	6,5	10	20	76	50
254.A63.M06.101	63	6	6,5	10	23	101	75
254.A63.M08.051	63	8	8,5	13	14,5	51	25
254.A63.M08.076	63	8	8,5	13	20	76	50
254.A63.M08.101	63	8	8,5	13	23	101	75
254.A63.M08.126	63	8	8,5	13	26	126	100
254.A63.M10.051	63	10	10,5	18	20	51	25
254.A63.M10.076	63	10	10,5	18	24	76	50
254.A63.M10.101	63	10	10,5	18	28	101	75
254.A63.M10.126	63	10	10,5	18	32	126	100
254.A63.M10.126Z	63	10	10,5	18	-	126	100
254.A63.M10.176	63	10	10,5	18	36,5	176	150
254.A63.M10.176Z	63	10	10,5	18	-	176	150
254.A63.M12.051	63	12	12,5	21	24	51	25
254.A63.M12.076	63	12	12,5	21	24	76	50
254.A63.M12.101	63	12	12,5	21	31	101	75
254.A63.M12.101Z	63	12	12,5	21	-	101	75
254.A63.M12.126	63	12	12,5	21	36	126	100
254.A63.M12.126Z	63	12	12,5	21	-	126	100
254.A63.M12.176	63	12	12,5	21	40	176	150
254.A63.M12.176Z	63	12	12,5	21	-	176	150
254.A63.M16.051	63	16	17	29	29	51	25
254.A63.M16.076	63	16	17	29	34	76	50
254.A63.M16.101	63	16	17	29	37	101	75
254.A63.M16.101Z	63	16	17	29	-	101	75
254.A63.M16.126	63	16	17	29	41	126	100
254.A63.M16.126Z	63	16	17	29	-	126	100
254.A63.M16.176	63	16	17	29	42,5	176	150
254.A63.M16.176Z	63	16	17	29	-	176	150

Bestell Nr. Code No.	HSK	M	d mm	d1 mm	D mm	A mm	L mm
-------------------------	-----	---	---------	----------	---------	---------	---------

254.A10.M08.079	100	8	8,5	13	23	79	50
254.A10.M10.079	100	10	10,5	18	23	79	50
254.A10.M10.129	100	10	10,5	18	32	129	100
254.A10.M10.129Z	100	10	10,5	18	-	129	100
254.A10.M10.179	100	10	10,5	18	36,5	179	150
254.A10.M10.179Z	100	10	10,5	18	-	179	150
254.A10.M12.079	100	12	12,5	21	24	79	50
254.A10.M12.129	100	12	12,5	21	33	129	100
254.A10.M12.129Z	100	12	12,5	21	-	129	100
254.A10.M12.179	100	12	12,5	21	40	179	150
254.A10.M12.179Z	100	12	12,5	21	-	179	150
254.A10.M16.079	100	16	17	29	34	79	50
254.A10.M16.129	100	16	17	29	36	129	100
254.A10.M16.129Z	100	16	17	29	-	129	100
254.A10.M16.179	100	16	17	29	42,5	179	150
254.A10.M16.179Z	100	16	17	29	-	179	150

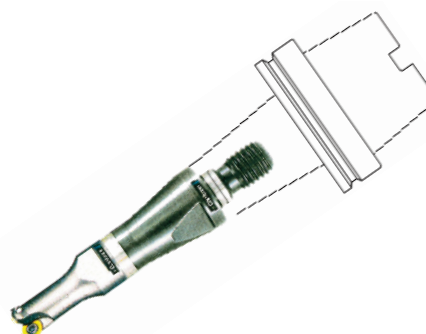
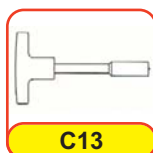



Bohrerhalter für Wendeplattenbohrer E1

HSK-A

Holder for drills with indexable inserts form E1

HSK-A

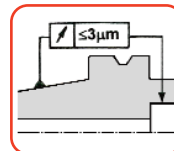
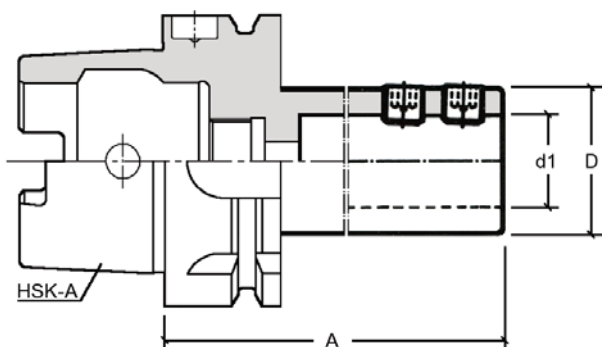

Bestell Nr. Code No.	HSK	d1 mm	A mm	D mm
227.A63.020.080	63	20	80	40
227.A63.025.090	63	25	90	45
227.A63.032.090	63	32	90	52
227.A63.040.105	63	40	105	60
227.A10.020.090	100	20	90	40
227.A10.025.095	100	25	95	45
227.A10.032.100	100	32	100	52
227.A10.040.110	100	40	110	60



C14



C13

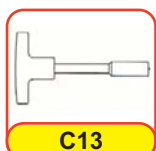

C13

Lieferumfang:
Mit Spannschraube(n)
Delivery:
With clamping screw(s)



NC-Bohrfutter für Rechts- und Linkslauf

HSK-A

NC-Drill chuck for right- and left hand rotation

HSK-A

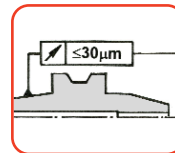
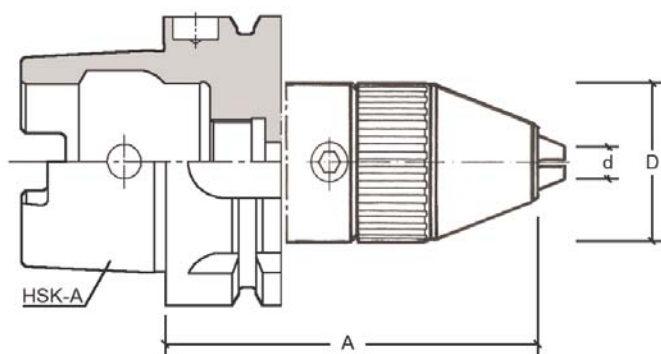

Bestell Nr. Code No.	HSK	Spannbereich Capacity d mm	A mm	D mm
342.A50.013.116	50	1-13	116	50
342.A50.016.121	50	3-16	121	57
342.A63.008.085	63	0-8	85	36
342.A63.013.104	63	1-13	104	50
342.A63.016.109	63	3-16	109	50
342.A80.013.109	80	1-13	109	50
342.A80.016.114	80	3-16	114	57
342.A10.013.107	100	1-13	107	50
342.A10.016.112	100	3-16	112	50

Höchste Präzision sowie genauester Rundlauf, mechanische Spannkraftverstärkung garantiert eine sichere Spannung. Während der Bearbeitung, ob Rechts- oder Linkslauf sowie bei Spindelstop, ist ein selbständiges Lösen nicht möglich.
 High precision and accurate concentricity, mechanical amplification is the guarantee of the very high clamping force.
 During the working process, if with right- or left-hand rotation or spindle stop, no automatic slackening will be possible.



C13

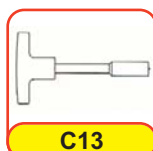

C13



Gewindeschneidfutter mit Längenausgleich auf Druck und Zug

HSK-A

Quick-change tapping chucks with length compensation

HSK-A

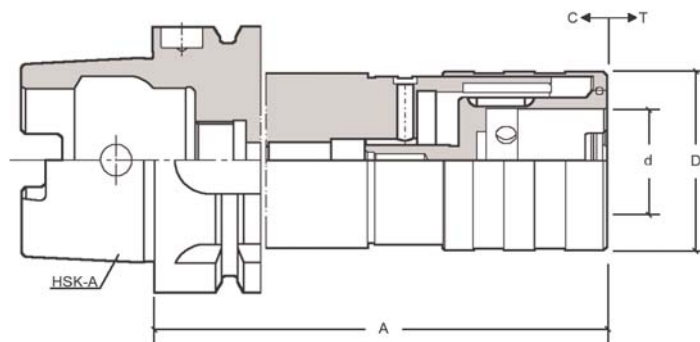

Bestell Nr. Code No.	HSK	Spannbereich Capacity	d mm	A mm	D mm	C mm	T mm
340.A50.019.105	50	M2-M14	19	105	36,5	7	7
340.A50.031.151	50	M5-M24	31	151	53,5	12	12
340.A63.019.104	63	M2-M14	19	104	36,5	7	7
340.A63.031.152	63	M5-M24	31	152	53,5	12	12
340.A10.019.112	100	M2-M14	19	112	36,5	7	7
340.A10.031.155	100	M5-M24	31	155	53,5	12	12
340.A10.048.188	100	M14-M36	48	188	78	17,5	17,5



C13

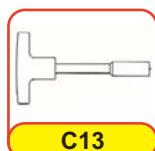

C13



C11



C12



Gewindeschneidfutter ohne Längenausgleich auf Druck und Zug

HSK-A

Quick-change tapping chucks without length compensation

HSK-A

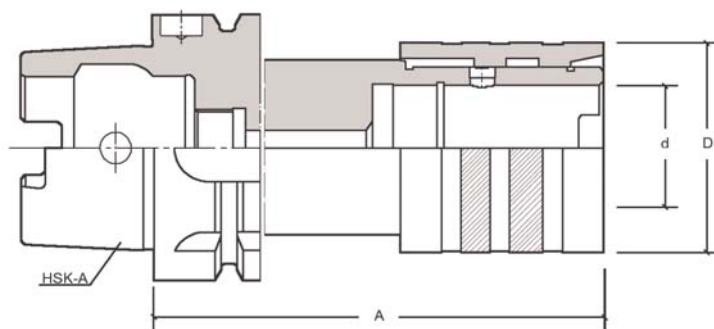

Bestell Nr. Code No.	HSK	Spannbereich Capacity	d mm	A mm	D mm
350.A50.019.065	50	M2-14	19	65	38
350.A50.031.100	50	M5-M24	31	100	52
350.A63.019.072	63	M2-M14	19	72	38
350.A63.031.110	63	M5-M24	31	110	52
350.A10.019.080	100	M2-M14	19	80	38
350.A10.031.100	100	M5-M24	31	100	52



C13

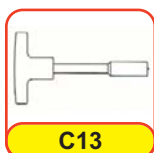

C13



C11



C12



Schrumpffutter zum Spannen von HM und HSS Schäften

HSK-A

Shrink chucks for mounting solid carbide and HSS shanks

HSK-A

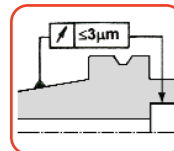
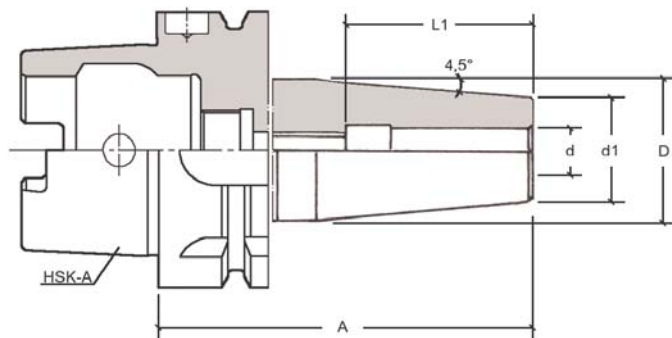

Bestell Nr. Code No.	HSK	d mm	A mm	d1 mm	D mm	L1 mm
-------------------------	-----	---------	---------	----------	---------	----------

271.A32.003.060	32	3	60	10	16	14
271.A32.004.060	32	4	60	12	18	17
271.A32.005.060	32	5	60	12	18	20
271.A32.006.070	32	6	70	21	25	36
271.A32.008.070	32	8	70	21	25	36
271.A32.010.070	32	10	70	24	29	42
271.A32.012.080	32	12	80	24	29	47

Bestell Nr. Code No.	HSK	d mm	A mm	d1 mm	D mm	L1 mm
-------------------------	-----	---------	---------	----------	---------	----------

271.A40.003.060	40	3	60	10	16	14
271.A40.003.120*	40	3	120	10	16	9
271.A40.003.160*	40	3	160	10	16	9
271.A40.004.060	40	4	60	12	18	17
271.A40.004.120*	40	4	120	12	20	12
271.A40.004.160*	40	4	160	12	20	12
271.A40.005.060	40	5	60	12	18	20
271.A40.005.120*	40	5	120	12	22	15
271.A40.005.160*	40	5	160	12	22	15
271.A40.006.080	40	6	80	21	27	36
271.A40.006.120	40	6	120	21	27	36
271.A40.006.160	40	6	160	21	27	36
271.A40.008.080	40	8	80	21	27	36
271.A40.008.120	40	8	120	21	27	36
271.A40.008.160	40	8	160	21	27	36
271.A40.010.080	40	10	80	24	32	42
271.A40.010.120	40	10	120	24	32	42
271.A40.010.160	40	10	160	24	32	42
271.A40.012.090	40	12	90	24	32	47
271.A40.012.120	40	12	120	24	32	47
271.A40.012.160	40	12	160	24	32	47
271.A40.014.090	40	14	90	27	34	47
271.A40.014.120	40	14	120	27	34	47
271.A40.014.160	40	14	160	27	34	47
271.A40.016.090	40	16	90	27	34	50
271.A40.016.120	40	16	120	27	34	50
271.A40.016.160	40	16	160	27	34	50

Bestell Nr. Code No.	HSK	d mm	A mm	d1 mm	D mm	L1 mm
-------------------------	-----	---------	---------	----------	---------	----------

271.A50.003.080	50	3	80	10	16	14
271.A50.003.120*	50	3	120	10	16	9
271.A50.003.160*	50	3	160	10	16	9
271.A50.004.080	50	4	80	12	20	17
271.A50.004.120*	50	4	120	12	20	12
271.A50.004.160*	50	4	160	12	20	12
271.A50.005.080	50	5	80	12	20,5	20
271.A50.005.120*	50	5	120	12	22	15
271.A50.005.160*	50	5	160	12	22	15
271.A50.006.080	50	6	80	21	27	36
271.A50.006.120	50	6	120	21	27	36
271.A50.006.160	50	6	160	21	27	36
271.A50.008.080	50	8	80	21	27	36
271.A50.008.120	50	8	120	21	27	36
271.A50.008.160	50	8	160	21	27	36
271.A50.010.085	50	10	85	24	32	42
271.A50.010.120	50	10	120	24	32	42
271.A50.010.160	50	10	160	24	32	42
271.A50.012.090	50	12	90	24	32	47
271.A50.012.120	50	12	120	24	32	47
271.A50.012.160	50	12	160	24	32	47
271.A50.014.090	50	14	90	27	34	47
271.A50.014.120	50	14	120	27	34	47
271.A50.014.160	50	14	160	27	34	47
271.A50.016.095	50	16	95	27	34	50
271.A50.016.120	50	16	120	27	34	50
271.A50.016.160	50	16	160	27	34	50
271.A50.018.095	50	18	95	33	42	50
271.A50.018.120	50	18	120	33	42	50
271.A50.018.160	50	18	160	33	42	50
271.A50.020.100	50	20	100	33	42	52
271.A50.020.120	50	20	120	33	42	52
271.A50.020.160	50	20	160	33	42	52

* Einstellschraube nicht enthalten

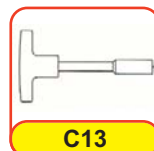



Schrumpffutter zum Spannen von HM und HSS Schäften

HSK-A

Shrink chucks for mounting solid carbide and HSS shanks

HSK-A

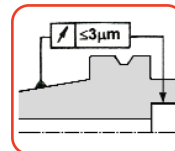
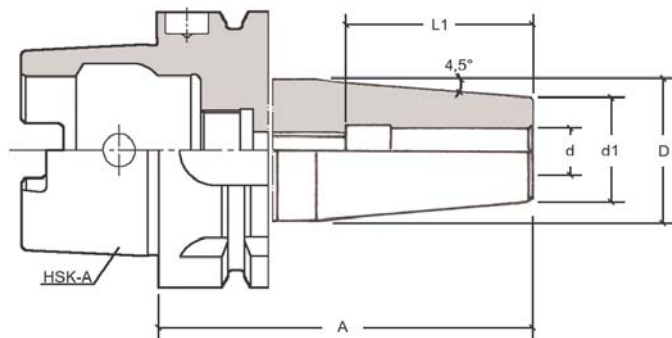

Bestell Nr. Code No.	HSK	d mm	A mm	d1 mm	D mm	L1 mm
-------------------------	-----	---------	---------	----------	---------	----------

271.A63.003.080	63	3	80	10	16	14
271.A63.003.120*	63	3	120	10	16	9
271.A63.003.160*	63	3	160	10	16	9
271.A63.004.080	63	4	80	12	20	17
271.A63.004.120*	63	4	120	12	20	12
271.A63.004.160*	63	4	160	12	20	12
271.A63.005.080	63	5	80	12	20,5	20
271.A63.005.120*	63	5	120	12	22	15
271.A63.005.160*	63	5	160	12	22	15
271.A63.006.080	63	6	80	21	27	36
271.A63.006.120	63	6	120	21	27	36
271.A63.006.160	63	6	160	21	27	36
271.A63.006.200	63	6	200	21	27	36
271.A63.008.080	63	8	80	21	27	36
271.A63.008.120	63	8	120	21	27	36
271.A63.008.160	63	8	160	21	27	36
271.A63.008.200	63	8	200	21	27	36
271.A63.010.085	63	10	85	24	32	42
271.A63.010.120	63	10	120	24	32	42
271.A63.010.160	63	10	160	24	32	42
271.A63.010.200	63	10	200	24	32	42
271.A63.012.090	63	12	90	24	32	47
271.A63.012.120	63	12	120	24	32	47
271.A63.012.160	63	12	160	24	32	47
271.A63.012.200	63	12	200	24	32	47

Bestell Nr. Code No.	HSK	d mm	A mm	d1 mm	D mm	L1 mm
-------------------------	-----	---------	---------	----------	---------	----------

271.A63.014.090	63	14	90	27	34	47
271.A63.014.120	63	14	120	27	34	47
271.A63.014.160	63	14	160	27	34	47
271.A63.014.200	63	14	200	27	34	47
271.A63.016.095	63	16	95	27	34	50
271.A63.016.120	63	16	120	27	34	50
271.A63.016.160	63	16	160	27	34	50
271.A63.016.200	63	16	200	27	34	50
271.A63.018.095	63	18	95	33	42	50
271.A63.018.120	63	18	120	33	42	50
271.A63.018.160	63	18	160	33	42	50
271.A63.018.200	63	18	200	33	42	50
271.A63.020.100	63	20	100	33	42	52
271.A63.020.120	63	20	120	33	42	52
271.A63.020.160	63	20	160	33	42	52
271.A63.020.200	63	20	200	33	42	52
271.A63.025.115	63	25	115	44	53	58
271.A63.025.130	63	25	130	44	53	58
271.A63.025.160	63	25	160	44	53	58
271.A63.025.200	63	25	200	44	53	58
271.A63.032.120	63	32	120	44	53	62
271.A63.032.160	63	32	160	44	53	62
271.A63.032.200	63	32	200	44	53	62

* Einstellschraube nicht enthalten

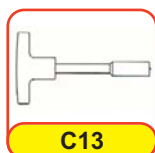



Schrumpffutter zum Spannen von HM und HSS Schäften

HSK-A

Shrink chucks for mounting solid carbide and HSS shanks

HSK-A

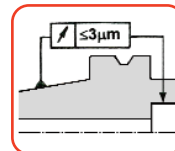
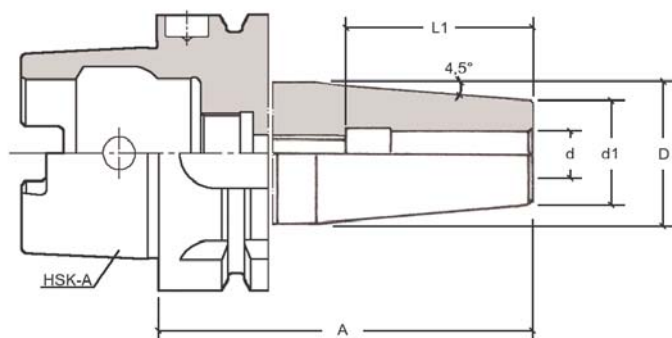

Bestell Nr. Code No.	HSK	d mm	A mm	d1 mm	D mm	L1 mm
-------------------------	-----	---------	---------	----------	---------	----------

271.A80.006.085	80	6	85	21	27	36
271.A80.006.120	80	6	120	21	27	36
271.A80.006.160	80	6	160	21	27	36
271.A80.008.085	80	8	85	21	27	36
271.A80.008.120	80	8	120	21	27	36
271.A80.008.160	80	8	160	21	27	36
271.A80.010.090	80	10	90	24	32	42
271.A80.010.120	80	10	120	24	32	42
271.A80.010.160	80	10	160	24	32	42
271.A80.012.095	80	12	95	24	32	47
271.A80.012.120	80	12	120	24	32	47
271.A80.012.160	80	12	160	24	32	47
271.A80.014.095	80	14	95	27	34	47
271.A80.014.120	80	14	120	27	34	47
271.A80.014.160	80	14	160	27	34	47
271.A80.016.100	80	16	100	27	34	50
271.A80.016.120	80	16	120	27	34	50
271.A80.016.160	80	16	160	27	34	50
271.A80.018.100	80	18	100	33	42	50
271.A80.018.120	80	18	120	33	42	50
271.A80.018.160	80	18	160	33	42	50
271.A80.020.105	80	20	105	33	42	52
271.A80.020.120	80	20	120	33	42	52
271.A80.020.160	80	20	160	33	42	52
271.A80.025.115	80	25	115	44	53	58
271.A80.025.120	80	25	120	44	53	58
271.A80.025.160	80	25	160	44	53	58
271.A80.032.120	80	32	120	44	53	62
271.A80.032.160	80	32	160	44	53	62

Bestell Nr. Code No.	HSK	d mm	A mm	d1 mm	D mm	L1 mm
-------------------------	-----	---------	---------	----------	---------	----------

271.A10.006.085	100	6	85	21	27	36
271.A10.006.120	100	6	120	21	27	36
271.A10.006.160	100	6	160	21	27	36
271.A10.006.200	100	6	200	21	27	36
271.A10.008.085	100	8	85	21	27	36
271.A10.008.120	100	8	120	21	27	36
271.A10.008.160	100	8	160	21	27	36
271.A10.008.200	100	8	200	21	27	36
271.A10.010.090	100	10	90	24	32	42
271.A10.010.120	100	10	120	24	32	42
271.A10.010.160	100	10	160	24	32	42
271.A10.010.200	100	10	200	24	32	42
271.A10.012.095	100	12	95	24	32	47
271.A10.012.120	100	12	120	24	32	47
271.A10.012.160	100	12	160	24	32	47
271.A10.012.200	100	12	200	24	32	47
271.A10.014.095	100	14	95	27	34	47
271.A10.014.120	100	14	120	27	34	47
271.A10.014.160	100	14	160	27	34	47
271.A10.014.200	100	14	200	27	34	47
271.A10.016.100	100	16	100	27	34	50
271.A10.016.120	100	16	120	27	34	50
271.A10.016.160	100	16	160	27	34	50
271.A10.016.200	100	16	200	27	34	50
271.A10.018.100	100	18	100	33	42	50
271.A10.018.120	100	18	120	33	42	50
271.A10.018.160	100	18	160	33	42	50
271.A10.018.200	100	18	200	33	42	50
271.A10.020.105	100	20	105	33	42	52
271.A10.020.120	100	20	120	33	42	52
271.A10.020.160	100	20	160	33	42	52
271.A10.020.200	100	20	200	33	42	52
271.A10.025.115	100	25	115	44	53	58
271.A10.025.120	100	25	120	44	53	58
271.A10.025.160	100	25	160	44	53	58
271.A10.025.200	100	25	200	44	53	58
271.A10.032.120	100	32	120	44	53	62
271.A10.032.160	100	32	160	44	53	62
271.A10.032.200	100	32	200	44	53	62

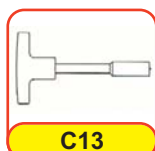



Schrumpffutter zum Spannen von HM und HSS Schäften

HSK-A

Shrink chucks for mounting solid carbide and HSS shanks

HSK-A

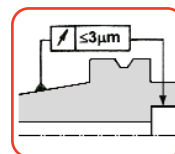
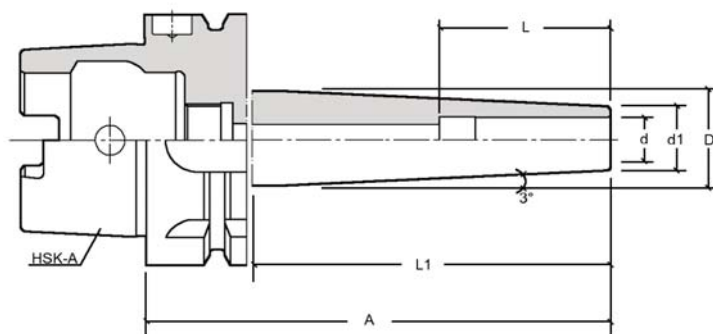

Bestell Nr. Code No.	HSK	d mm	A mm	d1 mm	D mm	L1 mm	L mm
272.A63.003.080	63	3	80	9	14	49	14
272.A63.003.120	63	3	120	9	18	89	9
272.A63.004.080	63	4	80	10	15	49	17
272.A63.004.120	63	4	120	10	19	89	12
272.A63.004.160	63	4	160	10	23	129	12
272.A63.005.080	63	5	80	11	16	49	20
272.A63.005.120	63	5	120	11	20	89	15
272.A63.005.160	63	5	160	11	24	129	15
272.A63.006.080	63	6	80	12	17	49	36
272.A63.006.120	63	6	120	12	21	89	36
272.A63.006.160	63	6	160	12	25	129	36
272.A63.008.080	63	8	80	14	19	49	36
272.A63.008.120	63	8	120	14	23	89	36
272.A63.008.160	63	8	160	14	27	129	36
272.A63.010.080	63	10	80	16	22	50	42
272.A63.010.085	63	10	85	16	22	50	42
272.A63.010.120	63	10	120	16	25	89	42
272.A63.010.160	63	10	160	16	29	129	42
272.A63.012.080	63	12	80	18	24	59	47
272.A63.012.090	63	12	90	18	24	59	47
272.A63.012.120	63	12	120	18	27	89	47
272.A63.012.160	63	12	160	18	31	129	47

Bestell Nr. Code No.	HSK	d mm	A mm	d1 mm	D mm	L1 mm	L mm
272.A10.006.085	100	6	85	12	17	47,5	36
272.A10.006.120	100	6	120	12	20,5	81	36
272.A10.006.160	100	6	160	12	24	124	36
272.A10.006.200	100	6	200	12	29	162	36
272.A10.008.085	100	8	85	14	19	57,5	36
272.A10.008.120	100	8	120	14	22,5	81	36
272.A10.008.160	100	8	160	14	27	124	36
272.A10.008.200	100	8	200	14	31	162	36
272.A10.010.090	100	10	90	16	21,5	52,5	42
272.A10.010.120	100	10	120	16	24,5	81	42
272.A10.010.160	100	10	160	16	29	124	42
272.A10.010.200	100	10	200	16	33	162	42
272.A10.012.095	100	12	95	18	24	57	47
272.A10.012.120	100	12	120	18	26,5	81	47
272.A10.012.160	100	12	160	18	31	124	47
272.A10.012.200	100	12	200	18	35	162	47
272.A10.016.100	100	16	100	22	29	66,5	50
272.A10.016.120	100	16	120	22	31	85,5	50
272.A10.016.160	100	16	160	22	35	124	50
272.A10.016.200	100	16	200	22	39	162	50

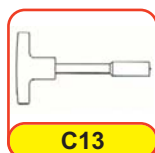



Schrumpffutter zum Spannen von HM und HSS Schäften

HSK-A

Shrink chucks for mounting solid carbide and HSS shanks

HSK-A

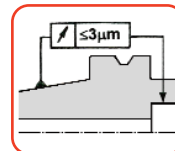
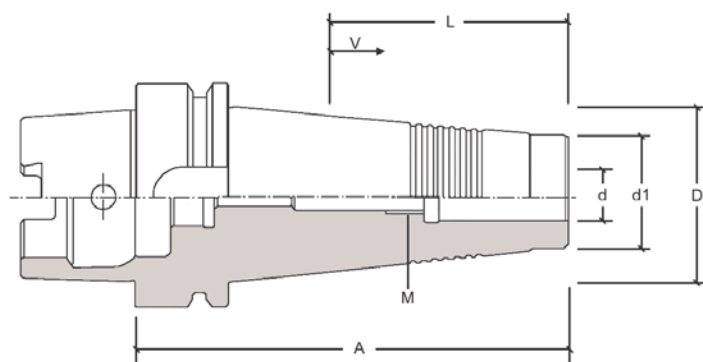
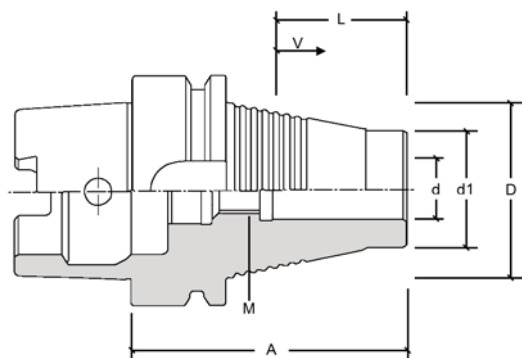

Bestell Nr. Code No.	HSK	d mm	A mm	d1 mm	D mm	M	V mm	L mm
273.A63.003.065	63	3	65	10	22	6	5	20
273.A63.003.126	63	3	126	10	28	6	5	20
273.A63.004.065	63	4	65	12	23	6	5	20
273.A63.004.126	63	4	126	10	28	6	5	20
273.A63.005.065	63	5	65	14	24	6	5	20
273.A63.005.126	63	5	126	11	30	6	5	25
273.A63.006.065	63	6	65	22	26	5	10	36
273.A63.006.126	63	6	126	12	30	5	10	36
273.A63.006.176	63	6	176	12	40	5	10	36
273.A63.006.226	63	6	226	12	50	5	10	36
273.A63.008.070	63	8	70	24	28	6	10	36
273.A63.008.126	63	8	126	16	34	6	10	36
273.A63.008.176	63	8	176	16	43	6	10	36
273.A63.008.226	63	8	226	16	42	6	10	36
273.A63.010.070	63	10	70	26	35	6	10	42
273.A63.010.126	63	10	126	20	38	8x1	10	42
273.A63.010.176	63	10	176	20	45	8x1	10	42
273.A63.010.226	63	10	226	20	52	8x1	10	42

Bestell Nr. Code No.	HSK	d mm	A mm	d1 mm	D mm	M	V mm	L mm
273.A63.012.070	63	12	70	28	42	-	-	45
273.A63.012.126	63	12	126	25	42	10x1	10	47
273.A63.012.176	63	12	176	25	47	8x1	10	47
273.A63.012.226	63	12	226	25	52	10x1	10	47
273.A63.014.070	63	14	70	31	44	-	-	45
273.A63.016.075	63	16	75	32	48	-	-	50
273.A63.016.126	63	16	126	29	52	12x1	10	50
273.A63.016.176	63	16	176	29	52	12x1	10	50
273.A63.016.226	63	16	226	29	52	12x1	10	50
273.A63.018.075	63	18	75	35	50	-	-	50
273.A63.020.080	63	20	80	36	52	-	-	52
273.A63.025.085	63	25	85	41	52	-	-	58
273.A63.032.100	63	32	100	49	52	-	-	62



C14



C13

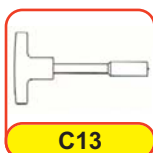

C13



Schrumpffutter zum Spannen von HM und HSS Schäften

HSK-A

Shrink chucks for mounting solid carbide and HSS shanks

HSK-A

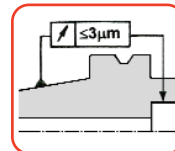
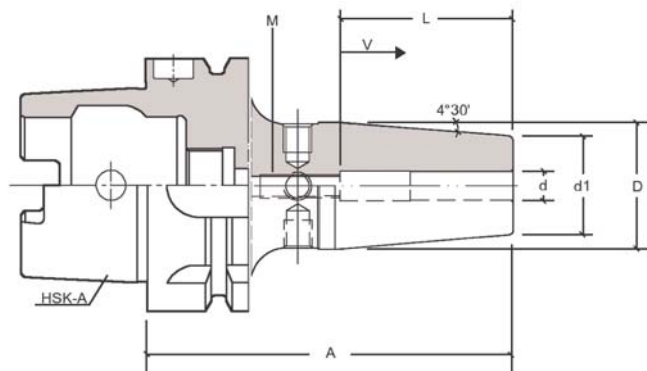

Bestell Nr. Code No.	HSK	M	d mm	A mm	d1 mm	D mm	V mm	L mm
280.A40.003.060	40	-	3	60	12	17	-	-
280.A40.004.060	40	-	4	60	12	17	-	-
280.A40.005.060	40	-	5	60	12	17	-	-
280.A40.006.080	40	5	6	80	21	27	10	37
280.A40.008.080	40	6	8	80	21	27	10	37
280.A40.010.080	40	8x1	10	80	24	32	10	42
280.A40.012.090	40	10x1	12	90	24	32	10	48
280.A40.014.090	40	10x1	14	90	27	34	10	48
280.A40.016.090	40	12x1	16	90	27	34	10	51
280.A50.003.060	50	-	3	60	12	17	-	-
280.A50.004.060	50	-	4	60	12	17	-	-
280.A50.005.060	50	-	5	60	12	17	-	-
280.A50.006.080	50	5	6	80	21	27	10	37
280.A50.008.080	50	6	8	80	21	27	10	37
280.A50.010.085	50	8x1	10	85	24	32	10	42
280.A50.012.090	50	10x1	12	90	24	32	10	48
280.A50.014.090	50	10x1	14	90	27	34	10	48
280.A50.016.095	50	12x1	16	95	27	34	10	51
280.A50.018.095	50	12x1	18	95	33	42	10	51
280.A50.020.100	50	16x1	20	100	33	42	10	53

Mit vier zusätzlichen Gewinden am Umfang zum nachträglichen Feinwuchten.
With four additional threads on the scope for subsequent fine balancing.

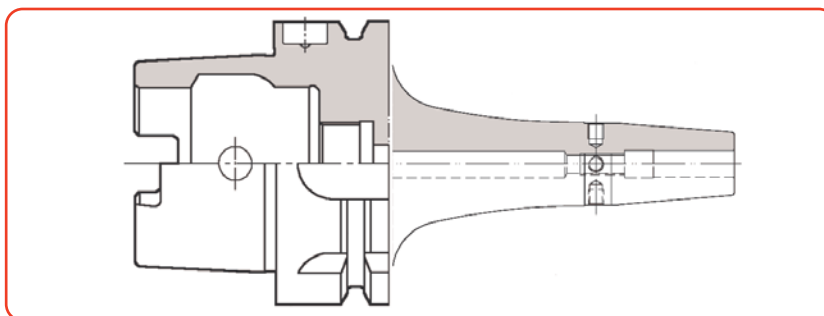

C14



C13

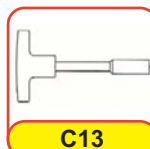

C13



Schrumpffutter zum Spannen von HM und HSS Schäften

HSK-A

Shrink chucks for mounting solid carbide and HSS shanks

HSK-A

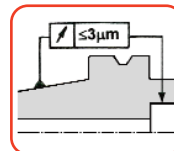
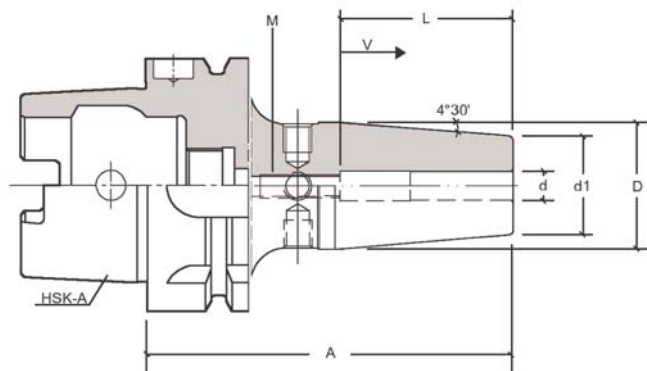

Mit vier zusätzlichen Gewinden am Umfang zum nachträglichen Feinwuchten.
With four additional threads on the scope for subsequent fine balancing.

Bestell Nr. Code No.	HSK	M	d mm	A mm	d1 mm	D mm	V mm	L mm
280.A63.003.080	63	-	3	80	12	17	-	-
280.A63.003.120	63	-	3	120	12	17	-	-
280.A63.003.130	63	-	3	130	12	-	-	-
280.A63.003.160	63	-	3	160	12	17	-	-
280.A63.004.080	63	-	4	80	12	17	-	-
280.A63.004.120	63	-	4	120	12	17	-	-
280.A63.004.130	63	-	4	130	12	-	-	-
280.A63.004.160	63	-	4	160	12	17	-	-
280.A63.005.080	63	-	5	80	12	17	-	-
280.A63.005.120	63	-	5	120	12	17	-	-
280.A63.005.130	63	-	5	130	12	-	-	-
280.A63.005.160	63	-	5	160	12	17	-	-
280.A63.006.080	63	5	6	80	21	27	10	37
280.A63.006.120	63	5	6	120	21	27	10	37
280.A63.006.130	63	5	6	130	21	27	10	37
280.A63.006.160	63	5	6	160	21	27	10	37
280.A63.006.200	63	5	6	200	21	27	10	37
280.A63.008.080	63	6	8	80	21	27	10	37
280.A63.008.120	63	6	8	120	21	27	10	37
280.A63.008.130	63	6	8	130	21	27	10	37
280.A63.008.160	63	6	8	160	21	27	10	37
280.A63.008.200	63	6	8	200	21	27	10	37
280.A63.010.085	63	8x1	10	85	24	32	10	42
280.A63.010.120	63	8x1	10	120	24	32	10	42
280.A63.010.130	63	8x1	10	130	24	32	10	42
280.A63.010.160	63	8x1	10	160	24	32	10	42
280.A63.010.200	63	8x1	10	200	24	32	10	42
280.A63.012.090	63	10x1	12	90	24	32	10	48
280.A63.012.120	63	10x1	12	120	24	32	10	48

Bestell Nr. Code No.	HSK	M	d mm	A mm	d1 mm	D mm	V mm	L mm
280.A63.012.130	63	10x1	12	130	24	32	10	48
280.A63.012.160	63	10x1	12	160	24	32	10	48
280.A63.012.200	63	10x1	12	200	24	32	10	48
280.A63.014.090	63	10x1	14	90	27	34	10	48
280.A63.014.120	63	10x1	14	120	27	34	10	48
280.A63.014.130	63	10x1	14	130	27	34	10	48
280.A63.014.160	63	10x1	14	160	27	34	10	48
280.A63.014.200	63	10x1	14	200	27	34	10	48
280.A63.016.095	63	12x1	16	95	27	34	10	51
280.A63.016.120	63	12x1	16	120	27	34	10	51
280.A63.016.130	63	12x1	16	130	27	34	10	51
280.A63.016.160	63	12x1	16	160	27	34	10	51
280.A63.016.200	63	12x1	16	200	27	34	10	51
280.A63.018.095	63	12x1	18	95	33	42	10	51
280.A63.018.120	63	12x1	18	120	33	42	10	51
280.A63.018.130	63	12x1	18	130	33	42	10	51
280.A63.018.160	63	12x1	18	160	33	42	10	51
280.A63.018.200	63	12x1	18	200	33	42	10	51
280.A63.020.100	63	16x1	20	100	33	42	10	53
280.A63.020.120	63	16x1	20	120	33	42	10	53
280.A63.020.130	63	16x1	20	130	33	42	10	53
280.A63.020.160	63	16x1	20	160	33	42	10	53
280.A63.020.200	63	16x1	20	200	33	42	10	53
280.A63.025.115	63	16x1	25	115	44	53	10	59
280.A63.025.130	63	16x1	25	130	44	53	10	59
280.A63.025.160	63	16x1	25	160	44	53	10	59
280.A63.025.200	63	16x1	25	200	44	53	10	59
280.A63.032.120	63	16x1	32	120	44	53	10	63
280.A63.032.160	63	16x1	32	160	44	53	10	63

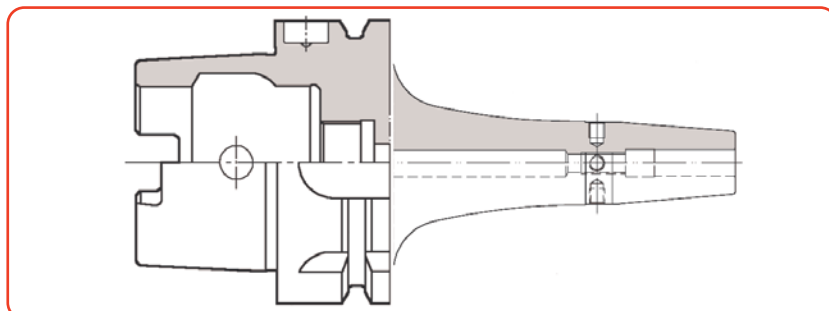



Schrumpffutter zum Spannen von HM und HSS Schäften

HSK-A

Shrink chucks for mounting solid carbide and HSS shanks

HSK-A

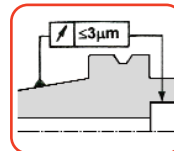
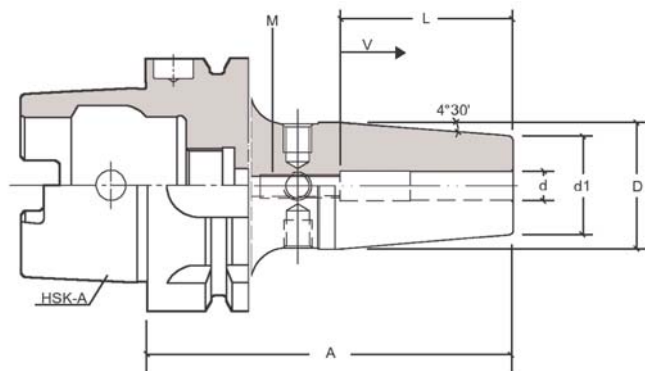

Bestell Nr. Code No.	HSK	M	d mm	A mm	d1 mm	D mm	V mm	L mm
280.A80.006.085	80	5	6	85	21	27	10	37
280.A80.006.160	80	5	6	160	21	27	10	37
280.A80.008.085	80	6	8	85	21	27	10	37
280.A80.008.160	80	6	8	160	21	27	10	37
280.A80.010.090	80	8x1	10	90	24	32	10	42
280.A80.010.160	80	8x1	10	160	24	32	10	42
280.A80.012.095	80	10x1	12	95	24	32	10	48
280.A80.012.160	80	10x1	12	160	24	32	10	48
280.A80.014.095	80	10x1	14	95	27	34	10	48
280.A80.016.100	80	12x1	16	100	27	34	10	51
280.A80.016.160	80	12x1	16	160	27	34	10	51
280.A80.018.100	80	12x1	18	100	33	42	10	51
280.A80.020.105	80	16x1	20	105	33	42	10	53
280.A80.020.160	80	16x1	20	160	33	42	10	53
280.A80.025.115	80	16x1	25	115	44	53	10	59
280.A80.025.160	80	16x1	25	160	44	53	10	59
280.A80.032.120	80	16x1	32	120	44	53	10	63

Mit vier zusätzlichen Gewinden am Umfang zum nachträglichen Feinwuchten.
With four additional threads on the scope for subsequent fine balancing.

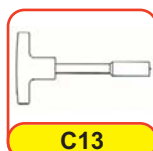
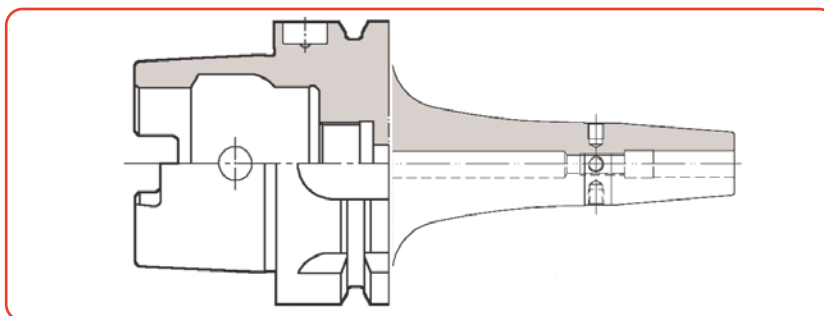



Schrumpffutter zum Spannen von HM und HSS Schäften

HSK-A

Shrink chucks for mounting solid carbide and HSS shanks

HSK-A

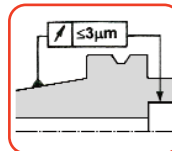
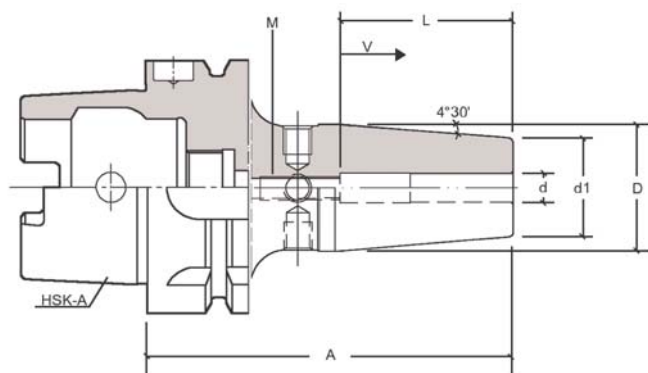

Bestell Nr. Code No.	HSK	M	d mm	A mm	d1 mm	D mm	V mm	L mm
280.A10.006.085	100	5	6	85	21	27	10	37
280.A10.006.120	100	5	6	120	21	27	10	37
280.A10.006.130	100	5	6	130	21	27	10	37
280.A10.006.160	100	5	6	160	21	27	10	37
280.A10.006.200	100	5	6	200	21	27	10	37
280.A10.008.085	100	6	8	85	21	27	10	37
280.A10.008.120	100	6	8	120	21	27	10	37
280.A10.008.130	100	6	8	130	21	27	10	37
280.A10.008.160	100	6	8	160	21	27	10	37
280.A10.008.200	100	6	8	200	21	27	10	37
280.A10.010.090	100	8x1	10	90	24	32	10	42
280.A10.010.120	100	8x1	10	120	24	32	10	42
280.A10.010.130	100	8x1	10	130	24	32	10	42
280.A10.010.160	100	8x1	10	160	24	32	10	42
280.A10.010.200	100	8x1	10	200	24	32	10	42
280.A10.012.095	100	10x1	12	95	24	32	10	48
280.A10.012.120	100	10x1	12	120	24	32	10	48
280.A10.012.130	100	10x1	12	130	24	32	10	48
280.A10.012.160	100	10x1	12	160	24	32	10	48
280.A10.012.200	100	10x1	12	200	24	32	10	48
280.A10.014.095	100	10x1	14	95	27	34	10	48
280.A10.014.120	100	10x1	14	120	27	34	10	48
280.A10.014.130	100	10x1	14	130	27	34	10	48
280.A10.014.160	100	10x1	14	160	27	34	10	48
280.A10.014.200	100	10x1	14	200	27	34	10	48

Bestell Nr. Code No.	HSK	M	d mm	A mm	d1 mm	D mm	V mm	L mm
280.A10.016.100	100	12x1	16	100	27	34	10	51
280.A10.016.120	100	12x1	16	120	27	34	10	51
280.A10.016.130	100	12x1	16	130	27	34	10	51
280.A10.016.160	100	12x1	16	160	27	34	10	51
280.A10.016.200	100	12x1	16	200	27	34	10	51
280.A10.018.100	100	12x1	18	100	33	42	10	51
280.A10.018.120	100	12x1	18	120	33	42	10	51
280.A10.018.130	100	12x1	18	130	33	42	10	51
280.A10.018.160	100	12x1	18	160	33	42	10	51
280.A10.018.200	100	12x1	18	200	33	42	10	51
280.A10.020.105	100	16x1	20	105	33	42	10	53
280.A10.020.120	100	16x1	20	120	33	42	10	53
280.A10.020.130	100	16x1	20	130	33	42	10	53
280.A10.020.160	100	16x1	20	160	33	42	10	53
280.A10.020.200	100	16x1	20	200	33	42	10	53
280.A10.025.115	100	16x1	25	115	44	53	10	59
280.A10.025.130	100	16x1	25	130	44	53	10	59
280.A10.025.160	100	16x1	25	160	44	53	10	59
280.A10.025.200	100	16x1	25	200	44	53	10	59
280.A10.032.120	100	16x1	32	120	44	53	10	63
280.A10.032.160	100	16x1	32	160	44	53	10	63
280.A10.032.200	100	16x1	32	200	44	53	10	63

Mit vier zusätzlichen Gewinden am Umfang zum nachträglichen Feinwuchten.
With four additional threads on the scope for subsequent fine balancing.

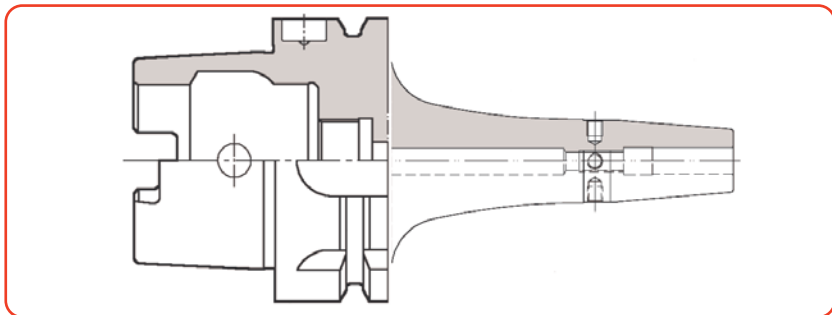



Schrumpffutter für HM und HSS Schäfte mit Kühlkanälen

HSK-A

Shrink chucks with cooling for solid carbide and HSS shanks

HSK-A

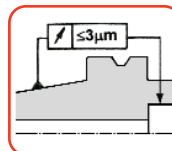
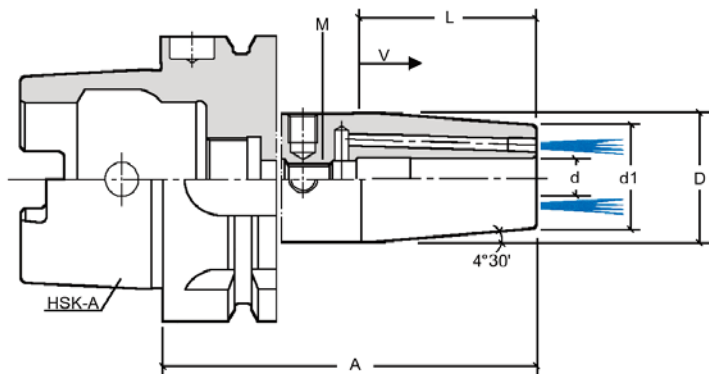

Bestell Nr. Code No.	HSK	M	d mm	A mm	d1 mm	D mm	V mm	L mm
281.A63.003.080	63	-	3	80	21	27	-	-
281.A63.003.130	63	-	3	130	12	-	-	-
281.A63.004.080	63	-	4	80	21	27	-	-
281.A63.004.130	63	-	4	130	12	-	-	-
281.A63.005.080	63	-	5	80	24	32	-	-
281.A63.005.130	63	-	5	130	12	-	-	-
281.A63.006.080	63	5	6	80	21	27	10	37
281.A63.006.120	63	5	6	120	21	27	10	37
281.A63.006.130	63	5	6	130	21	27	10	37
281.A63.008.080	63	6	8	80	21	27	10	37
281.A63.008.120	63	6	8	120	21	27	10	37
281.A63.008.130	63	6	8	130	21	27	10	37
281.A63.010.070	63	-	10	70	26	33	-	42
281.A63.010.085	63	8x1	10	85	24	32	10	42
281.A63.010.120	63	8x1	10	120	24	32	10	42
281.A63.010.130	63	8x1	10	130	24	32	10	42
281.A63.012.070	63	-	12	70	26	33	-	48
281.A63.012.090	63	10x1	12	90	24	32	10	48
281.A63.012.120	63	10x1	12	120	24	32	10	48
281.A63.012.130	63	10x1	12	130	24	32	10	48
281.A63.014.090	63	10x1	14	90	27	34	10	48
281.A63.014.120	63	10x1	14	120	27	34	10	48
281.A63.014.130	63	10x1	14	130	27	34	10	48
281.A63.016.075	63	-	16	75	29	37	-	51
281.A63.016.095	63	12x1	16	95	27	34	10	51
281.A63.016.120	63	12x1	16	120	27	34	10	51
281.A63.016.130	63	12x1	16	130	27	34	10	51
281.A63.018.095	63	12x1	18	95	33	42	10	51
281.A63.018.120	63	12x1	18	120	33	42	10	51
281.A63.018.130	63	12x1	18	130	33	42	10	51

Bestell Nr. Code No.	HSK	M	d mm	A mm	d1 mm	D mm	V mm	L mm
281.A63.020.075	63	-	20	75	35	43	-	53
281.A63.020.100	63	16x1	20	100	33	42	10	53
281.A63.020.120	63	16x1	20	120	33	42	10	53
281.A63.020.130	63	16x1	20	130	33	42	10	53
281.A63.025.085	63	-	25	85	45	50	-	59
281.A63.025.115	63	16x1	25	115	44	53	10	59
281.A63.025.130	63	16x1	25	130	44	53	10	59
281.A63.032.130	63	16x1	32	130	44	53	10	63
281.A10.006.085	100	5	6	85	21	27	10	37
281.A10.008.085	100	6	8	85	21	27	10	37
281.A10.010.090	100	8x1	10	90	24	32	10	42
281.A10.012.095	100	10x1	12	95	24	32	10	48
281.A10.014.095	100	10x1	14	95	27	34	10	48
281.A10.016.100	100	12x1	16	100	27	34	10	51
281.A10.018.100	100	12x1	18	100	33	42	10	51
281.A10.020.105	100	16x1	20	105	33	42	10	53
281.A10.025.115	100	16x1	25	115	44	53	10	59

Mit vier zusätzlichen Gewinden am Umfang zum nachträglichen Feinwuchten.
With four additional threads on the scope for subsequent fine balancing.





Schrumpffutter zum Spannen von HM und HSS Schäften

HSK-A

Shrink chucks for mounting solid carbide and HSS shanks

HSK-A

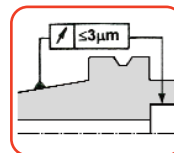
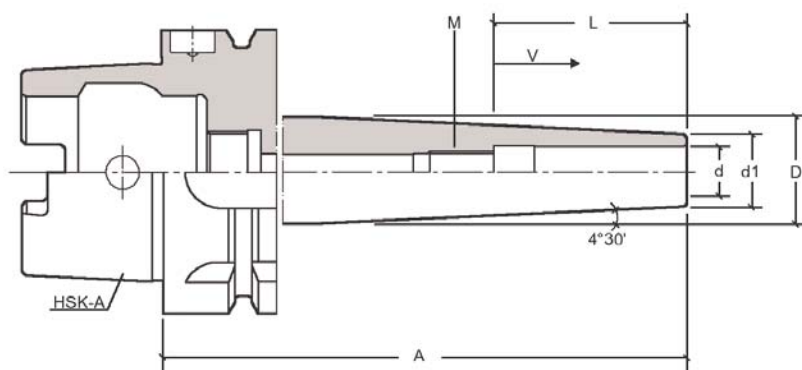

Bestell Nr. Code No.	HSK	M	d mm	A mm	d1 mm	D mm	V mm	L mm
282.A63.006.120	63	5	6	120	15	30	10	37
282.A63.008.120	63	6	8	120	15	30	10	37
282.A63.010.120	63	8x1	10	120	18	33	10	42
282.A63.012.120	63	10x1	12	120	18	33	10	48

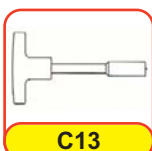



Hydro-Dehnspannfutter

Hydraulic expansibles chuck

HSK-A

HSK-A

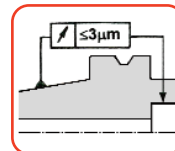
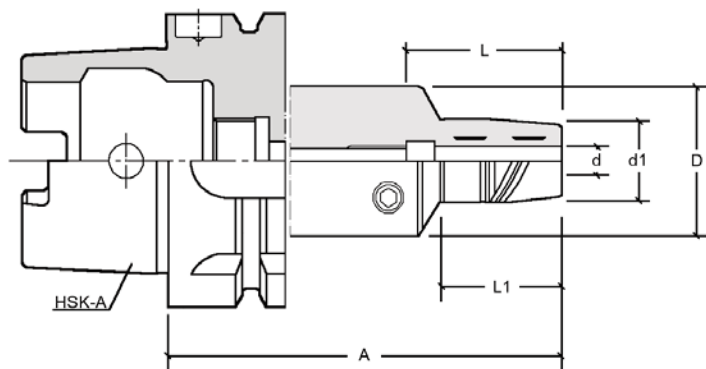

Bestell Nr. Code No.	HSK	d mm	A mm	d1 mm	L1 mm	L mm	D mm
260.A40.006.070	40	6	70	26	-	37	34
260.A40.008.070	40	8	70	28	-	37	34
260.A40.010.075	40	10	75	30	-	41	34
260.A40.012.080	40	12	80	32	-	46	34
260.A50.006.070	50	6	70	26	26	37	40
260.A50.008.070	50	8	70	28	26	37	40
260.A50.010.075	50	10	75	30	33	41	40
260.A50.012.085	50	12	85	32	40	46	40
260.A50.014.085	50	14	85	34	40	46	40
260.A50.016.090	50	16	90	38	46	49	42
260.A50.018.090	50	18	90	40	46	49	42
260.A50.020.090	50	20	90	42	64	51	42

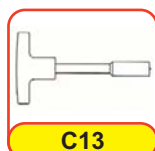



Hydro-Dehnspannfutter

Hydraulic expansibles chuck

HSK-A

HSK-A

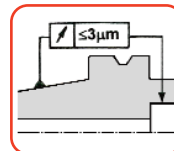
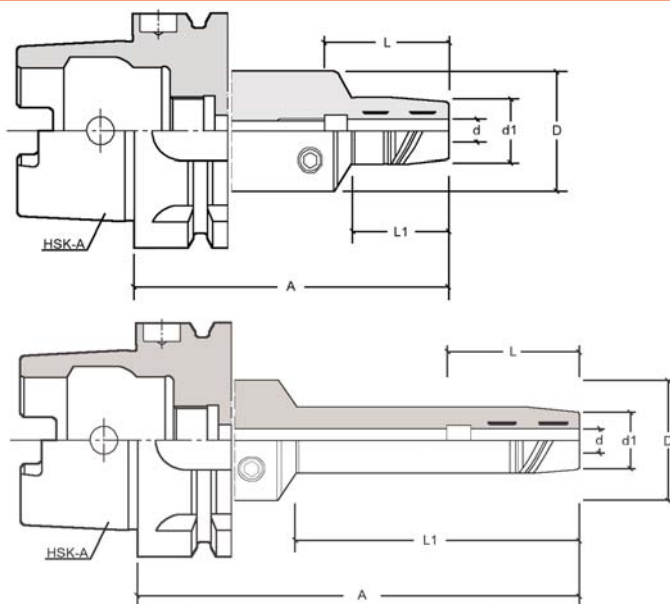

Bestell Nr. Code No.	HSK	d mm	A mm	d1 mm	L1 mm	L mm	D mm
260.A63.006.070	63	6	70	26	26	37	50
260.A63.006.150	63	6	150	26	105	37	50
260.A63.006.200	63	6	200	26	155	37	50
260.A63.008.070	63	8	70	28	26	37	50
260.A63.008.150	63	8	150	28	105	37	50
260.A63.008.200	63	8	200	28	155	37	50
260.A63.010.080	63	10	80	30	35	41	50
260.A63.010.150	63	10	150	30	105	41	50
260.A63.010.200	63	10	200	30	155	41	50
260.A63.012.085	63	12	85	32	40	46	50
260.A63.012.120	63	12	120	25	60	46	49,5
260.A63.012.150	63	12	150	32	105	46	50
260.A63.012.200	63	12	200	32	155	46	50
260.A63.014.085	63	14	85	34	40	46	50
260.A63.014.150	63	14	150	34	105	46	50
260.A63.014.200	63	14	200	34	155	46	50
260.A63.016.090	63	16	90	38	46	49	50
260.A63.016.150	63	16	150	38	105	49	50
260.A63.016.200	63	16	200	38	155	49	50
260.A63.018.090	63	18	90	40	46	49	50
260.A63.018.150	63	18	150	40	105	49	50
260.A63.018.200	63	18	200	40	155	49	50
260.A63.020.080	63	20	80	33	54	51	51,5
260.A63.020.090	63	20	90	42	46	51	50
260.A63.020.150	63	20	150	42	105	51	50
260.A63.020.200	63	20	200	42	155	51	50
260.A63.025.120	63	25	120	49,5	46	57	55
260.A63.032.125	63	32	125	56	99	61	63

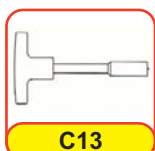



Hydro-Dehnspannfutter

HSK-A

Hydraulic expansibles chuck

HSK-A

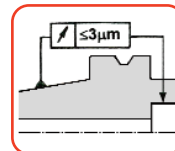
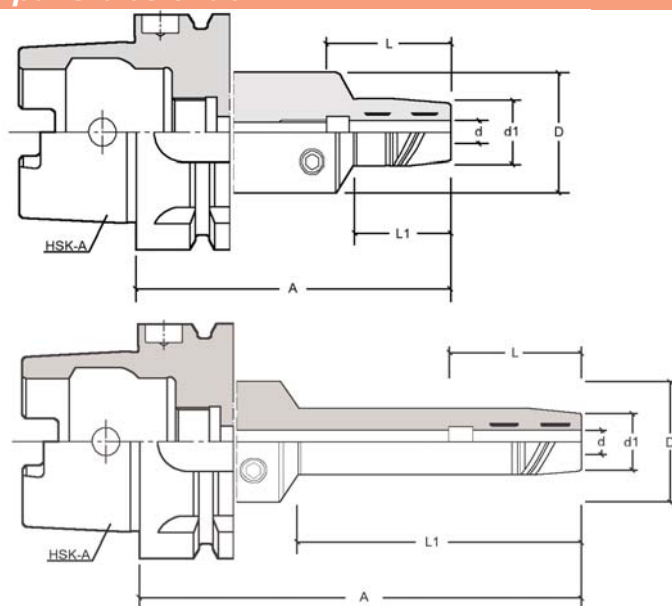

Bestell Nr. Code No.	HSK	d mm	A mm	d1 mm	L1 mm	L mm	D mm
260.A10.006.075	100	6	75	26	26	37	50
260.A10.006.150	100	6	150	26	100	37	50
260.A10.006.200	100	6	200	26	150	37	50
260.A10.008.075	100	8	75	28	26	37	50
260.A10.008.150	100	8	150	28	100	37	50
260.A10.008.200	100	8	200	28	150	37	50
260.A10.010.090	100	10	90	30	40	41	50
260.A10.010.150	100	10	150	30	100	41	50
260.A10.010.200	100	10	200	30	150	41	50
260.A10.012.095	100	12	95	32	40	46	50
260.A10.012.120	100	12	120	25	60	46	49,5
260.A10.012.150	100	12	150	32	100	46	50
260.A10.012.200	100	12	200	32	150	46	50
260.A10.014.095	100	14	95	34	40	46	50
260.A10.014.150	100	14	150	34	100	46	50
260.A10.014.200	100	14	200	34	150	46	50
260.A10.016.100	100	16	100	38	46	49	50
260.A10.016.150	100	16	150	38	100	49	50
260.A10.016.200	100	16	200	38	150	49	50
260.A10.018.100	100	18	100	40	46	49	50
260.A10.018.150	100	18	150	40	100	49	50
260.A10.018.200	100	18	200	40	150	49	50
260.A10.020.090	100	20	90	39	59	51	50
260.A10.020.105	100	20	105	42	46	51	50
260.A10.020.150	100	20	150	42	100	51	50
260.A10.020.200	100	20	200	42	150	51	50
260.A10.025.115	100	25	115	49,5	86	57	55
260.A10.032.100	100	32	100	61	71	61	70
260.A10.032.120	100	32	120	63	91	61	70

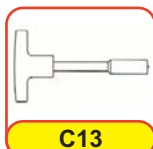



Rohlinge zur Anfertigung von Sonderwerkzeugen

HSK-A

Blanks for production of special tools

HSK-A

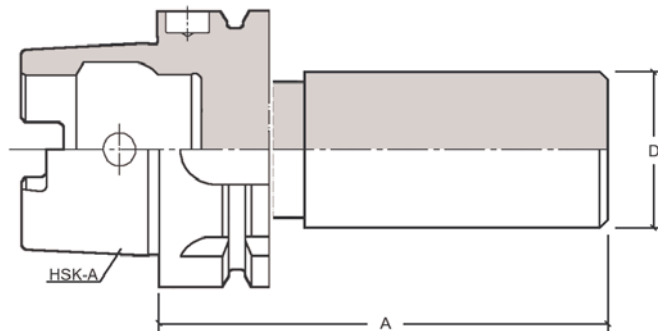

Bestell Nr. Code No.	HSK	D mm	A mm
361.A32.025.150	32	25	150
361.A32.032.100	32	32	100
361.A40.040.150	40	40	150
361.A40.070.100	40	70	100
361.A50.050.150	50	50	150
361.A50.075.070	50	75	70

Bestell Nr. Code No.	HSK	D mm	A mm
361.A63.063.160	63	63	160
361.A63.063.310	63	63	310
361.A63.080.250	63	80	250
361.A63.120.160	63	120	160
361.A80.080.250	80	80	250
361.A80.090.310	80	90	310
361.A10.097.250	100	97	250
361.A10.120.160	100	120	160
361.A10.120.315	100	120	315

Kontrolldorne

HSK-A

Test abors

HSK-A

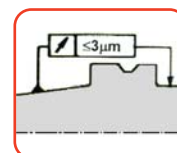
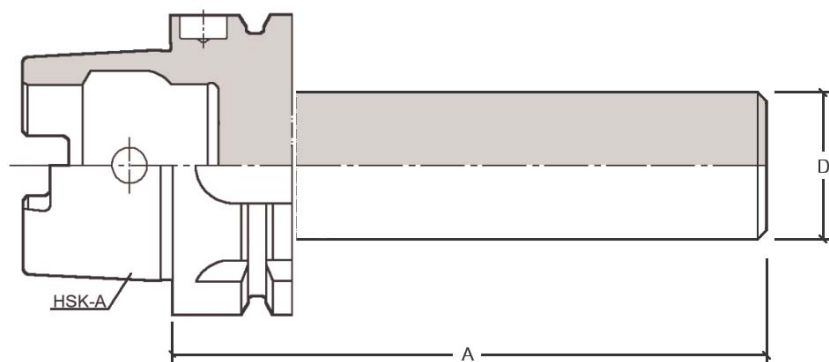

Bestell Nr. Code No.	HSK	D mm	A mm
898.A32.025.150	32	25	150
898.A40.025.150	40	25	150
898.A50.032.200	50	32	200
898.A63.040.300	63	40	300
898.A80.040.300	80	40	300
898.A10.050.300	100	50	300





ER-Spannfutter mit Zylinderschaft mit Standard Spannmutter

ER-Collet with cylindrical shank and with standard nut

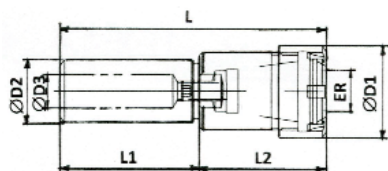
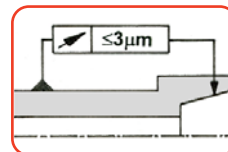
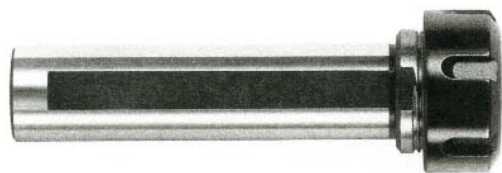

Bestell Nr. Code No.	$\varnothing D2$ h6	Spannbereich Capacity	$\varnothing D1$ mm	$\varnothing D3$ mm	L1 mm	L2 mm	L mm
ER16							
253.W16.N16.166	16	1-10	32	7	130	36	166
253.W20.N16.081	20	1-10	32	11	50	31	81
253.W20.N16.131	20	1-10	32	11	100	31	131
253.W20.N16.161	20	1-10	32	11	130	31	161
253.W25.N16.087	25	1-10	32	11	60	27	87
ER20							
253.W20.N20.082	20	1-13	35	11	46	36	82
253.W20.N20.096	20	1-13	35	11	60	36	96
253.W20.N20.136	20	1-13	35	11	100	36	136
253.W25.N20.088	25	1-13	35	13	60	28	88



Lieferumfang: Mit gewichteter Spannmutter und axialer Anschlagschraube
Delivery: With balanced clamping nut and axial stop screw



ER-Spannfutter mit Zylinderschaft mit Standard Spannmutter

ER-Collet with cylindrical shank and with standard nut

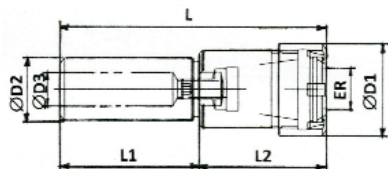
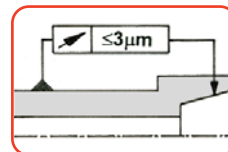
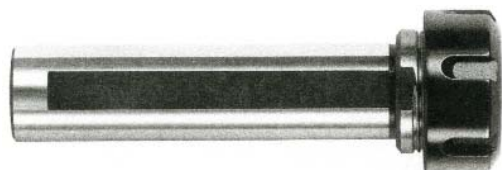

Bestell Nr. Code No.	$\varnothing D2$ h6	Spannbereich Capacity	$\varnothing D1$ mm	$\varnothing D3$ mm	L1 mm	L2 mm	L mm
ER25							
253.W16.N25.116	16	1-16	42	9	70	46	116
253.W20.N25.096	20	1-16	42	11	50	46	96
253.W20.N25.146	20	1-16	42	11	100	46	146
253.W20.N25.206	20	1-16	42	11	160	46	206
253.W25.N25.082	25	1-16	42	13	50	32	82
253.W25.N25.102	25	1-16	42	13	70	32	102
253.W25.N25.132	25	1-16	42	13	100	32	132
253.W25.N25.192	25	1-16	42	13	160	32	192
253.W32.N25.098	32	1-16	42	19	70	28	98
253.W32.N25.128	32	1-16	42	19	100	28	128
253.W32.N25.148	32	1-16	42	19	120	28	148
253.W32.N25.178	32	1-16	42	19	150	28	178
253.W40.N25.112	40	1-16	42	19	70	42	112
ER32							
253.W20.N32.104	20	2-20	50	13	50	54	104
253.W20.N32.154	20	2-20	50	13	100	54	154
253.W20.N32.214	20	2-20	50	13	160	54	214
253.W25.N32.104	25	2-20	50	13	50	54	104
253.W25.N32.124	25	2-20	50	13	70	54	124
253.W25.N32.154	25	2-20	50	13	100	54	154
253.W25.N32.184	25	2-20	50	13	130	54	184
253.W32.N32.088	32	2-20	50	23	50	38	88
253.W32.N32.108	32	2-20	50	23	70	38	108
253.W32.N32.138	32	2-20	50	23	100	38	138
253.W32.N32.158	32	2-20	50	23	120	38	158
253.W32.N32.188	32	2-20	50	23	150	38	188
253.W40.N32.100	40	2-20	50	23	70	30	100
253.W40.N32.130	40	2-20	50	23	100	30	130
253.W40.N32.160	40	2-20	50	23	130	30	160



C09-10



C16



C02-03-04



C14

Lieferumfang: Mit gewichteter Spannmutter und axialer Anschlagschraube
Delivery: With balanced clamping nut and axial stopscrew



ER-Spannfutter mit Zylinderschaft mit MINI Spannmutter

ER-Collet with cylindrical shank and with MINI nut

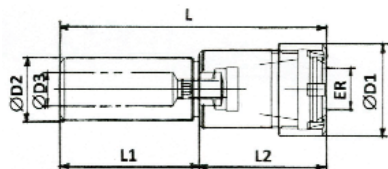
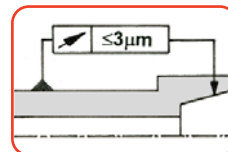

Bestell Nr. Code No.	ØD2 h6	Spannbereich Capacity	ØD1 mm	ØD3 mm	L1 mm	L2 mm	L mm
ER11							
253.W10.011.100	10	1-7	16	~	75	25	100
253.W12.011.100	12	1-7	16	~	75	25	100
253.W16.011.100	16	1-7	16	~	75	25	100
253.W16.011.130	16	1-7	16	~	105	25	130
253.W16.011.160	16	1-7	16	~	135	25	160
253.W20.011.050	20	1-7	16	~	25	25	50
253.W20.011.100	20	1-7	16	~	75	25	100
253.W20.011.130	20	1-7	16	~	105	25	130
253.W20.011.160	20	1-7	16	~	135	25	160
ER16							
253.W12.016.080	12	1-10	22	5	50	30	80
253.W12.016.120	12	1-10	22	5	90	30	120
253.W16.016.100	16	1-10	22	5	70	30	100
253.W16.016.130	16	1-10	22	5	100	30	130
253.W16.016.160	16	1-10	22	5	130	30	160
253.W16.016.200	16	1-10	22	5	170	30	200
253.W20.016.100	20	1-10	22	5	70	30	100
253.W20.016.130	20	1-10	22	5	100	30	130
253.W20.016.160	20	1-10	22	5	130	30	160
ER20							
253.W20.020.100	20	1-13	28	9	60	40	100
253.W20.020.160	20	1-13	28	9	120	40	160
253.W20.020.200	20	1-13	28	9	160	40	200
253.W25.020.160	25	1-13	28	9	120	40	160



C09



C16



C02-03-04



C14

Lieferumfang: Mit gewuchteter Spannmutter und axialer Anschlagschraube
Delivery: With balanced clamping nut and axial stopscrew



ER-Spannfutter mit Zylinderschaft mit MINI Spannmutter

ER-Collet with cylindrical shank and with MINI nut

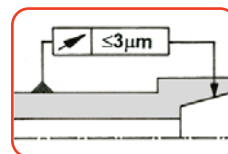
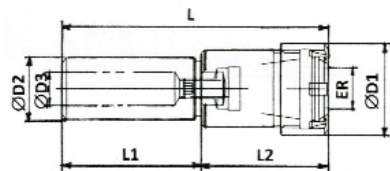

Bestell Nr. Code No.	ØD2 h6	Spannbereich Capacity	ØD1 mm	ØD3 mm	L1 mm	L2 mm	L mm
ER11							
253.006.011.070	6	1-7	16	~	45	25	70
253.007.011.070	7	1-7	16	~	45	25	70
253.008.011.080	8	1-7	16	~	55	25	80
253.008.011.125	8	1-7	16	~	100	25	125
253.010.011.080	10	1-7	16	5	55	25	80
253.010.011.105	10	1-7	16	5	80	25	105
253.010.011.125	10	1-7	16	5	100	25	125
253.010.011.155	10	1-7	16	5	130	25	155
253.012.011.080	12	1-7	16	7	55	25	80
253.012.011.095	12	1-7	16	7	70	25	95
253.012.011.125	12	1-7	16	7	100	25	125
253.012.011.165	12	1-7	16	7	140	25	165
253.016.011.062	16	1-7	16	7	40	22	62
253.016.011.082	16	1-7	16	7	60	22	82
253.016.011.102	16	1-7	16	7	80	22	102
253.016.011.122	16	1-7	16	7	100	22	122
253.016.011.152	16	1-7	16	7	130	22	152
253.016.011.182	16	1-7	16	7	160	22	182
253.016.011.222	16	1-7	16	7	200	22	222
ER16							
253.008.016.092	8	1-10	22	~	55	37	92
253.010.016.097	10	1-10	22	5	60	37	97
253.010.016.137	10	1-10	22	5	100	37	137
253.012.016.092	12	1-10	22	7	55	37	92
253.012.016.117	12	1-10	22	7	80	37	117
253.012.016.157	12	1-10	22	7	120	37	157
253.016.016.072	16	1-10	22	7	35	37	72
253.016.016.097	16	1-10	22	7	60	37	97
253.016.016.117	16	1-10	22	7	80	37	117
253.016.016.137	16	1-10	22	7	100	37	137
253.016.016.167	16	1-10	22	7	130	37	167
253.016.016.197	16	1-10	22	7	160	37	197
253.016.016.237	16	1-10	22	7	200	37	237
ER20							
253.016.020.095	16	1-13	28	9	55	40	95
253.016.020.140	16	1-13	28	9	100	40	140
253.016.020.200	16	1-13	28	9	160	40	200



C09



C16



C02-03-04



C14

Lieferumfang: Mit gewuchteter Spannmutter und axialer Anschlagschraube
Delivery: With balanced clamping nut and axial stop screw



Schrumpfverlängerungen ohne Längeneinstellschraube

Shrink fit extensions without length adjustment screw

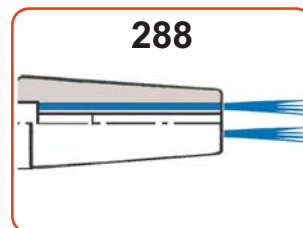
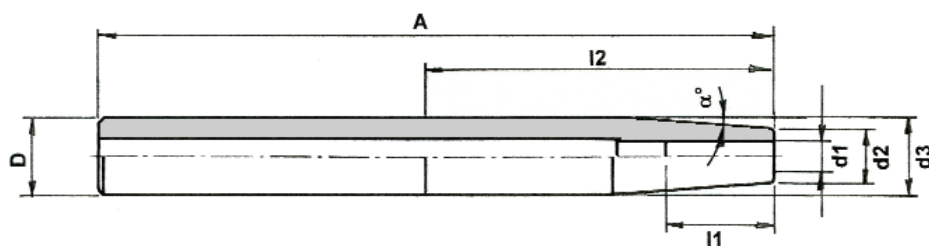

Bestell Nr. Code No.	D h6	d1 mm	d2 mm	d3 mm	α°	l1 mm	l2 mm	A mm
286.012.003.110	12	3	8	11,8	3°	12	63	110
286.012.003.160	12	3	8	12	4°30'	12	~	160
286.012.004.110	12	4	10	11,8	3°	16	63	110
286.012.004.160	12	4	8	12	4°30'	16	~	160
286.012.005.110	12	5	11	11,8	3°	20	63	110
286.016.003.160	16	3	10	16	4°30'	12	~	160
286.016.003.200	16	3	9	16	3°	12	150	200
286.016.004.160	16	4	10	16	4°30'	16	~	160
286.016.004.200	16	4	10	16	3°	16	150	200
286.016.005.160	16	5	10	16	4°30'	20	~	160
286.016.005.200	16	5	10	16	3°	20	150	200
286.016.006.160	16	6	10	16	4°30'	26	~	160
286.020.005.160	20	5	14	20	4°30'	20	~	160
286.020.006.160	20	6	14	20	4°30'	26	~	160
286.020.006.300	20	6	14	20	4°30'	26	~	300
286.020.008.160	20	8	14	20	4°30'	26	~	160
286.020.008.300	20	8	14	20	4°30'	26	~	300
286.025.008.160	25	8	19	25	4°30'	26	~	160
286.025.008.300	25	8	19	25	4°30'	26	~	300
286.025.010.160	25	10	20	25	4°30'	32	~	160
286.025.010.300	25	10	20	25	4°30'	32	~	300
286.025.012.160	25	12	20	25	4°30'	37	~	160
286.025.012.300	25	12	20	25	4°30'	37	~	300
286.025.014.160	25	14	20	25	4°30'	37	~	160
286.025.014.300	25	14	20	25	4°30'	37	~	300
286.025.016.160	25	16	22	25	4°30'	40	~	160
286.025.016.300	25	16	22	25	4°30'	40	~	300
286.032.010.160	32	10	24	32	4°30'	32	~	160
286.032.010.300	32	10	24	32	4°30'	32	~	300
286.032.012.160	32	12	24	32	4°30'	37	~	160
286.032.012.300	32	12	24	32	4°30'	37	~	300
286.032.014.160	32	14	27	32	4°30'	37	~	160
286.032.014.300	32	14	27	32	4°30'	37	~	300
286.032.016.160	32	16	27	32	4°30'	40	~	160
286.032.016.300	32	16	27	32	4°30'	40	~	300
286.032.018.160	32	18	27	32	4°30'	40	~	160
286.032.020.160	32	20	27	32	4°30'	42	~	160
286.032.020.300	32	20	27	32	4°30'	42	~	300
288.020.006.160	25	6	14	20	4°30'	26	~	160
288.025.008.160	25	8	19	25	4°30'	26	~	160
288.025.010.160	25	10	20	25	4°30'	32	~	160
288.032.010.160	32	10	24	32	4°30'	32	~	160
288.032.012.160	32	12	24	32	4°30'	37	~	160
288.032.014.160	32	14	27	32	4°30'	37	~	160
288.032.016.160	32	16	27	32	4°30'	40	~	160



Schrumpfverlängerungen mit Längeneinstellschraube

Shrink fit extensions with length adjustment screw

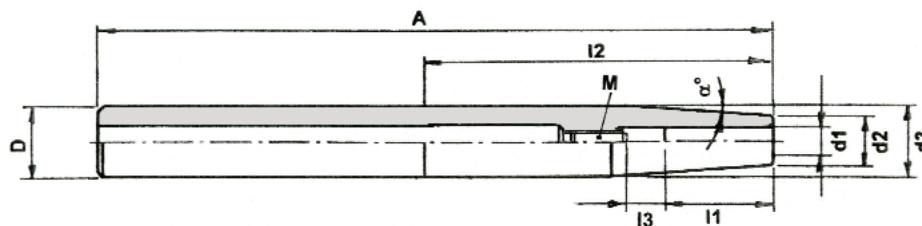

Bestell Nr. Code No.	D h6	d1 mm	d2 mm	d3 mm	α°	I1 mm	I2 mm	I3 mm	M	A mm
283.012.003.150	12	3	8	12	4°30'	12	~	~	M5	150
283.012.004.150	12	4	8	12	4°30'	16	~	~	M5	150
283.012.006.110	12	6	12	17	3°	26	63	10	M5	110
283.012.008.110	12	8	14	19	3°	26	63	10	M6	110
283.016.003.110	16	3	9	13	3°	12	60	10	M6	110
283.016.003.150	16	3	10	16	4°30'	12	~	~	M5	150
283.016.004.110	16	4	10	14	3°	16	60	10	M6	110
283.016.004.150	16	4	10	16	4°30'	16	~	~	M5	150
283.016.005.110	16	5	11	15	3°	20	58	10	M6	110
283.016.005.150	16	5	10	16	4°30'	20	~	~	M6	150
283.016.006.110	16	6	12	15,8	3°	26	60	10	M5	110
283.016.006.150	16	6	10	16	4°30'	26	~	10	M5	150
283.016.006.200	16	6	12	16	3°	26	150	10	M5	200
283.016.008.110	16	8	14	19	3°	26	60	10	M6	110
283.016.008.160	16	8	14	16	4°30'	26	~	10	M5	160
283.020.003.110	20	3	9	13	3°	12	58	10	M6	110
283.020.003.150	20	3	10	20	4°30'	12	~	~	M5	150
283.020.004.110	20	4	10	14	3°	16	58	10	M6	110
283.020.004.150	20	4	10	20	4°30'	16	~	~	M5	150
283.020.005.110	20	5	11	15	3°	20	58	10	M6	110
283.020.005.150	20	5	10	20	4°30'	20	~	~	M6	150
283.020.006.110	20	6	12	16	3°	26	58	10	M5	110
283.020.006.150	20	6	10	20	4°30'	26	~	10	M5	150
283.020.006.160	20	6	14	20	4°30'	26	~	10	M5	160
283.020.006.250	20	6	12	20	3°	26	198	10	M5	250
283.020.008.110	20	8	14	19	3°	26	58	10	M6	110
283.020.008.150	20	8	12	20	4°30'	26	~	10	M6	150
283.020.008.160	20	8	14	20	4°30'	26	~	10	M6	160
283.020.008.250	20	8	14	20	3°	26	198	10	M6	250
283.020.010.110	20	10	16	19,8	3°	32	58	10	M8x1	110
283.020.010.150	20	10	14	20	4°30'	32	~	10	M6	150
283.020.010.250	20	10	16	20	3°	32	198	10	M8x1	250
283.020.012.110	20	12	18	19,8	3°	37	58	10	M10x1	110
283.020.012.150	20	12	16	20	4°30'	37	~	10	M10x1	150





Schrumpfverlängerungen mit Längeneinstellschraube

Shrink fit extensions with length adjustment screw

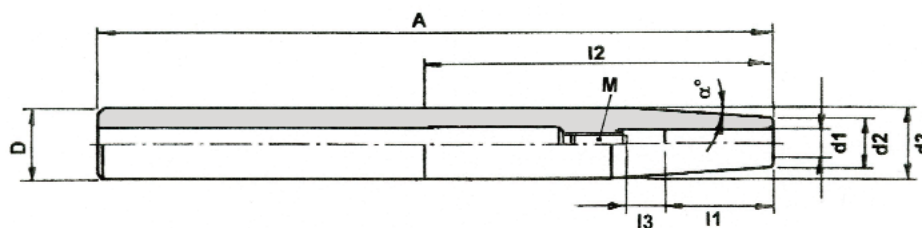

Bestell Nr. Code No.	D h6	d1 mm	d2 mm	d3 mm	α°	I1 mm	I2 mm	I3 mm	M	A mm
283.025.008.150	25	8	20	25	4°30'	26	~	10	M6	150
283.025.008.160	25	8	19	25	4°30'	26	~	10	M6	160
283.025.010.150	25	10	20	25	4°30'	32	~	10	M6	150
283.025.010.160	25	10	20	25	4°30'	32	~	10	M8x1	160
283.025.012.150	25	12	20	25	4°30'	37	~	10	M10x1	150
283.025.012.160	25	12	20	25	4°30'	37	~	10	M10x1	160
283.025.012.250	25	12	18	25	3°	37	193	10	M10x1	250
283.025.014.150	25	14	20	25	4°30'	37	~	10	M10x1	150
283.025.014.160	25	14	20	25	4°30'	37	~	10	M10x1	160
283.025.016.150	25	16	22	25	4°30'	40	~	10	M10x1	150
283.025.016.160	25	16	22	25	4°30'	40	~	10	M12x1	160
283.025.016.250	25	16	22	25	3°	40	193	10	M12x1	250
283.032.010.150	32	10	24	32	4°30'	32	~	10	M6	150
283.032.010.160	32	10	24	32	4°30'	32	~	10	M8x1	160
283.032.012.150	32	12	24	32	4°30'	37	~	10	M10x1	150
283.032.012.160	32	12	24	32	4°30'	37	~	10	M10x1	160
283.032.014.150	32	14	27	32	4°30'	37	~	10	M10x1	150
283.032.014.160	32	14	27	32	4°30'	37	~	10	M10x1	160
283.032.016.150	32	16	27	32	4°30'	40	~	10	M10x1	150
283.032.016.160	32	16	27	32	4°30'	40	~	10	M12x1	160
283.032.018.150	32	18	27	32	4°30'	40	~	10	M10x1	150
283.032.018.160	32	18	27	32	4°30'	40	~	10	M12x1	160
283.032.020.150	32	20	27	32	4°30'	42	~	10	M10x1	150
283.032.020.160	32	20	27	32	4°30'	42	~	10	M16x1	160





Fräsdorne mit Zyl.Schaft nach DIN 1835A + B für Einschraubfräser

Milling arbors with shank to DIN 1835A + B for screw in tools

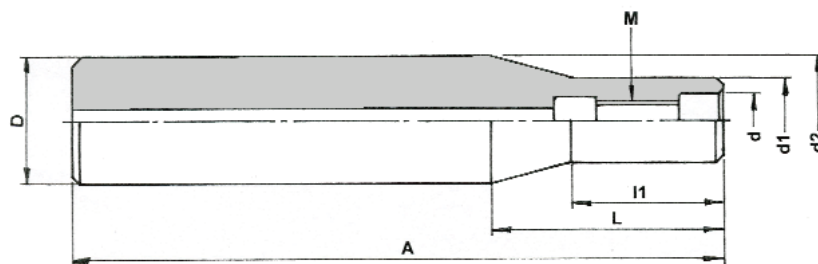

Bestell Nr. Code No.	D mm	M	d mm	d1 mm	d2 mm	l1 mm	A mm	L mm
267.020.M10.160	20	M10	10,5	18,5	20	67	160	68,7
267.025.M12.240	25	M12	12,5	23	25	77	240	87,5
267.032.M12.160	32	M12	12,5	23	32	23	160	54
267.032.M12.300	32	M12	12,5	23	32	59,5	300	134
267.032.M16.160	32	M16	17,0	30	32	66	160	68,7
267.032.M16.300	32	M16	17,0	30	32	146	300	148,7

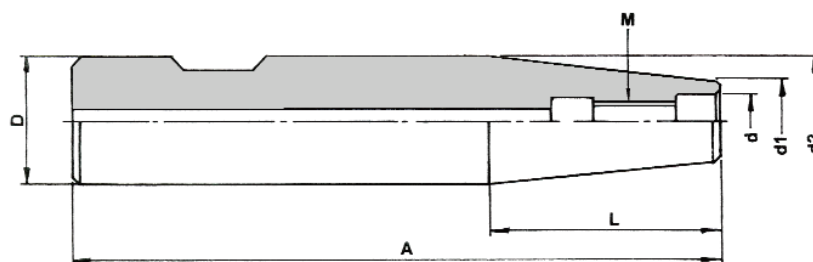

Bestell Nr. Code No.	D mm	M	d mm	d1 mm	d2 mm	A mm	L mm
267.W20.M06.075	20	M6	6,5	10	18	75	25
267.W20.M06.100	20	M6	6,5	10	18	100	50
267.W20.M06.125	20	M6	6,5	10	18	125	75
267.W16.M08.088	16	M8	8,5	13	16	88	40
267.W20.M08.075	20	M8	8,5	13	18	75	25
267.W20.M08.100	20	M8	8,5	13	18	100	50
267.W20.M08.125	20	M8	8,5	13	18	125	75
267.W20.M10.075	20	M10	10,5	18	18	75	25
267.W20.M10.080	20	M10	10,5	18,5	20	80	25
267.W20.M10.100	20	M10	10,5	18	18	100	50
267.W20.M10.125	20	M10	10,5	18	18	125	75
267.W20.M10.152	20	M10	10,5	18,5	20	152	97
267.W25.M12.081	25	M12	12,5	21	25	81	35
267.W25.M12.101	25	M12	12,5	23	25	101	40
267.W25.M12.131	25	M12	12,5	21	25	131	75
267.W25.M12.170	25	M12	12,5	23	25	170	109
267.W25.M12.181	25	M12	12,5	21	25	181	125
267.W32.M12.170	32	M12	12,5	23	25	170	170
267.W32.M16.085	32	M16	17,0	29	32	85	25
267.W32.M16.105	32	M16	17,0	30	32	105	40
267.W32.M16.135	32	M16	17,0	29	32	135	75
267.W32.M16.185	32	M16	17,0	29	32	185	125



Verlängerungen für Einschraubfräser

Extensions for screw in tools

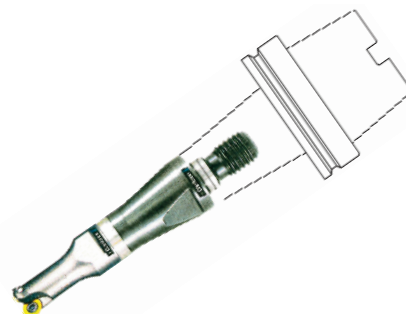
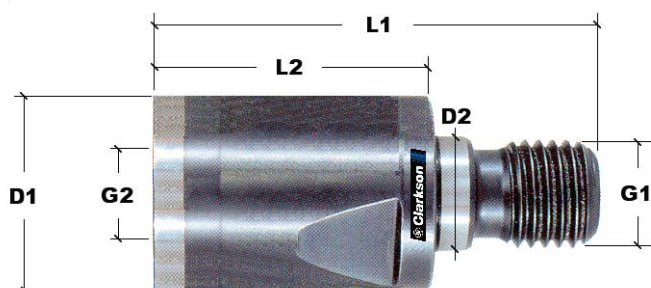

Bestell Nr. Code No.	G1 M	G2 M	D1 mm	D2 mm	L1 mm	L2 mm
257.M06.M06.025	M6	M6	9,8	6,5	40	25
257.M08.M08.030	M8	M8	12,8	8,5	48	30
257.M10.M10.A35	M10	M10	15,4	10,5	55	35
257.M10.M10.035	M10	M10	17,8	10,5	55	35
257.M12.M12.040	M12	M12	20,8	12,5	62	40
257.M16.M16.045	M16	M16	28,8	17,0	64	45

Reduzierung für Einschraubfräser

Reductions for screw in tools

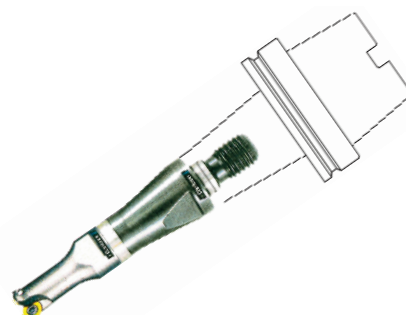
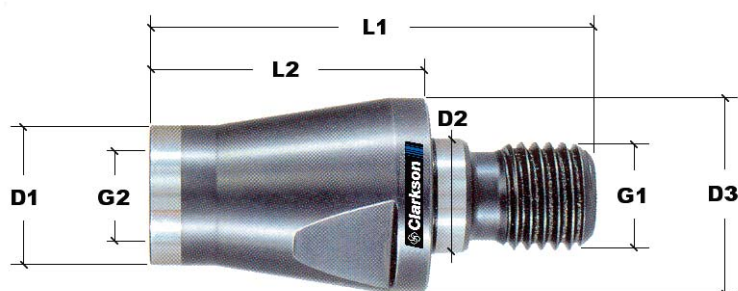

Bestell Nr. Code No.	G1 M	G2 M	D1 mm	D2 mm	D3 mm	L1 mm	L2 mm
258.M08.M06.025	M8	M6	9,8	8,5	12,8	43	25
258.M10.M08.030	M10	M8	12,8	10,5	17,8	50	30
258.M12.M06.040	M12	M6	9,8	12,5	20,8	62	40
258.M12.M08.040	M12	M8	12,8	12,5	20,8	62	40
258.M12.M10.035	M12	M10	15,4	12,5	20,8	57	35
258.M12.M10.A35	M12	M10	17,8	12,5	20,8	57	35
258.M16.M08.060	M16	M8	12,8	17,0	28,8	84	60
258.M16.M10.060	M16	M10	15,4	17,0	28,8	84	60
258.M16.M10.A60	M16	M10	17,8	17,0	28,8	84	60
258.M16.M12.040	M16	M12	20,8	17,0	28,8	64	40



Reduziereinsätze DIN 1835B für Zylinderschäfte DIN 1835B + E

Reducing bushes DIN 1835B for cylindrical shanks DIN 1835B + E

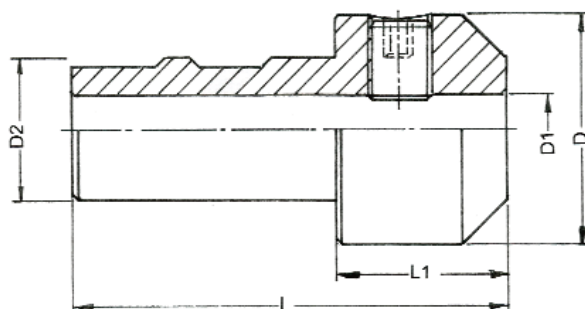

Form: AD
mit Durchgangsbohrung

Bestell Nr. Code No.	D1 mm	D2 h6	D mm	L1 mm	L mm
276.020.006.030	6	20	25	30	80
276.020.008.030	8	20	28	30	80
276.020.010.030	10	20	35	30	80
276.020.012.035	12	20	42	35	85

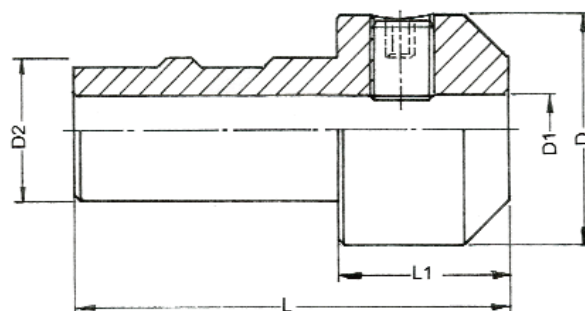

Bestell Nr. Code No.	D1 mm	D2 h6	D mm	L1 mm	L mm
276.032.006.030	6	32	25	30	90
276.032.008.030	8	32	28	30	90
276.032.010.030	10	32	35	30	90
276.032.012.035	12	32	42	35	95
276.032.014.035	14	32	44	35	95
276.032.016.038	16	32	48	38	98
276.032.018.038	18	32	50	38	98
276.032.020.040	20	32	52	40	100



C14



Spannzangen DIN 6388 B (ISO 10897 B) System OZ

Collets DIN 6388 B (ISO 10897 B) OZ system

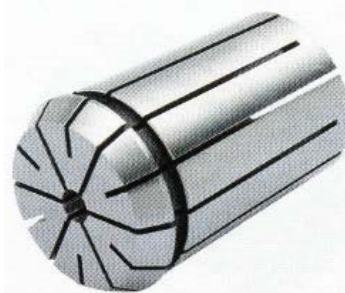
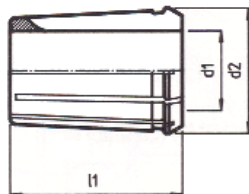

Bestell Nr. Code No.	Größe Size	d1 mm	d2 mm	l1 mm
-------------------------	---------------	----------	----------	----------

OZ 16				
435.016.002.000	OZ 16	2	25,5	40
435.016.003.000	OZ 16	3	25,5	40
435.016.004.000	OZ 16	4	25,5	40
435.016.005.000	OZ 16	5	25,5	40
435.016.006.000	OZ 16	6	25,5	40
435.016.007.000	OZ 16	7	25,5	40
435.016.008.000	OZ 16	8	25,5	40
435.016.009.000	OZ 16	9	25,5	40
435.016.010.000	OZ 16	10	25,5	40
435.016.011.000	OZ 16	11	25,5	40
435.016.012.000	OZ 16	12	25,5	40
435.016.013.000	OZ 16	13	25,5	40
435.016.014.000	OZ 16	14	25,5	40
435.016.015.000	OZ 16	15	25,5	40
435.016.016.000	OZ 16	16	25,5	40

OZ 25				
435.025.002.000	OZ 25	2	35,05	52
435.025.003.000	OZ 25	3	35,05	52
435.025.004.000	OZ 25	4	35,05	52
435.025.005.000	OZ 25	5	35,05	52
435.025.006.000	OZ 25	6	35,05	52
435.025.007.000	OZ 25	7	35,05	52
435.025.008.000	OZ 25	8	35,05	52
435.025.009.000	OZ 25	9	35,05	52
435.025.010.000	OZ 25	10	35,05	52
435.025.011.000	OZ 25	11	35,05	52
435.025.012.000	OZ 25	12	35,05	52
435.025.013.000	OZ 25	13	35,05	52
435.025.014.000	OZ 25	14	35,05	52
435.025.015.000	OZ 25	15	35,05	52
435.025.016.000	OZ 25	16	35,05	52
435.025.017.000	OZ 25	17	35,05	52
435.025.018.000	OZ 25	18	35,05	52
435.025.019.000	OZ 25	19	35,05	52
435.025.020.000	OZ 25	20	35,05	52
435.025.021.000	OZ 25	21	35,05	52
435.025.022.000	OZ 25	22	35,05	52
435.025.023.000	OZ 25	23	35,05	52
435.025.024.000	OZ 25	24	35,05	52
435.025.025.000	OZ 25	25	35,05	52

Bestell Nr. Code No.	Größe Size	d1 mm	d2 mm	l1 mm
-------------------------	---------------	----------	----------	----------

OZ 32				
435.032.003.000	OZ 32	3	43,7	60
435.032.004.000	OZ 32	4	43,7	60
435.032.005.000	OZ 32	5	43,7	60
435.032.006.000	OZ 32	6	43,7	60
435.032.007.000	OZ 32	7	43,7	60
435.032.008.000	OZ 32	8	43,7	60
435.032.009.000	OZ 32	9	43,7	60
435.032.010.000	OZ 32	10	43,7	60
435.032.011.000	OZ 32	11	43,7	60
435.032.012.000	OZ 32	12	43,7	60
435.032.013.000	OZ 32	13	43,7	60
435.032.014.000	OZ 32	14	43,7	60
435.032.015.000	OZ 32	15	43,7	60
435.032.016.000	OZ 32	16	43,7	60
435.032.017.000	OZ 32	17	43,7	60
435.032.018.000	OZ 32	18	43,7	60
435.032.019.000	OZ 32	19	43,7	60
435.032.020.000	OZ 32	20	43,7	60
435.032.021.000	OZ 32	21	43,7	60
435.032.022.000	OZ 32	22	43,7	60
435.032.023.000	OZ 32	23	43,7	60
435.032.024.000	OZ 32	24	43,7	60
435.032.025.000	OZ 32	25	43,7	60
435.032.026.000	OZ 32	26	43,7	60
435.032.027.000	OZ 32	27	43,7	60
435.032.028.000	OZ 32	28	43,7	60
435.032.029.000	OZ 32	29	43,7	60
435.032.030.000	OZ 32	30	43,7	60
435.032.031.000	OZ 32	31	43,7	60
435.032.032.000	OZ 32	32	43,7	60



Spannzangen DIN 6499 B (ISO 15488 B) System ER

Collets DIN 6499 B (ISO 15488 B) ER system

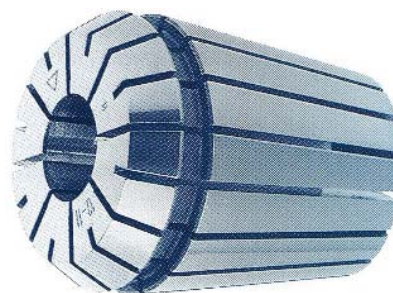
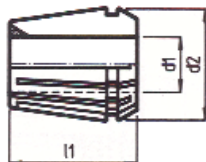

Bestell Nr. Code No.	Größe Size	d1 mm	d2 mm	l1 mm
-------------------------	---------------	----------	----------	----------

ER 8

228.008.001.000	ER 8	1	8,5	13,6
228.008.001.500	ER 8	1,5	8,5	13,6
228.008.002.000	ER 8	2	8,5	13,6
228.008.002.500	ER 8	2,5	8,5	13,6
228.008.003.000	ER 8	3	8,5	13,6
228.008.003.500	ER 8	3,5	8,5	13,6
228.008.004.000	ER 8	4	8,5	13,6
228.008.004.500	ER 8	4,5	8,5	13,6
228.008.005.000	ER 8	5	8,5	13,6

ER 11

228.011.001.000	ER 11	1	11,5	18
228.011.001.500	ER 11	1,5	11,5	18
228.011.002.000	ER 11	2	11,5	18
228.011.002.500	ER 11	2,5	11,5	18
228.011.003.000	ER 11	3	11,5	18
228.011.003.500	ER 11	3,5	11,5	18
228.011.004.000	ER 11	4	11,5	18
228.011.004.500	ER 11	4,5	11,5	18
228.011.005.000	ER 11	5	11,5	18
228.011.005.500	ER 11	5,5	11,5	18
228.011.006.000	ER 11	6	11,5	18
228.011.006.500	ER 11	6,5	11,5	18
228.011.007.000	ER 11	7	11,5	18

ER 16

228.016.001.000	ER 16	1	17	27,5
228.016.001.500	ER 16	1,5	17	27,5
228.016.002.000	ER 16	2	17	27,5
228.016.002.500	ER 16	2,5	17	27,5
228.016.003.000	ER 16	3	17	27,5
228.016.003.500	ER 16	3,5	17	27,5
228.016.004.000	ER 16	4	17	27,5
228.016.004.500	ER 16	4,5	17	27,5
228.016.005.000	ER 16	5	17	27,5
228.016.005.500	ER 16	5,5	17	27,5
228.016.006.000	ER 16	6	17	27,5
228.016.006.500	ER 16	6,5	17	27,5
228.016.007.000	ER 16	7	17	27,5
228.016.007.500	ER 16	7,5	17	27,5
228.016.008.000	ER 16	8	17	27,5
228.016.008.500	ER 16	8,5	17	27,5
228.016.009.000	ER 16	9	17	27,5
228.016.009.500	ER 16	9,5	17	27,5
228.016.010.000	ER 16	10	17	27,5

Bestell Nr. Code No.	Größe Size	d1 mm	d2 mm	l1 mm
-------------------------	---------------	----------	----------	----------

ER 20

228.020.002.000	ER 20	2	21	31,5
228.020.002.500	ER 20	2,5	21	31,5
228.020.003.000	ER 20	3	21	31,5
228.020.003.500	ER 20	3,5	21	31,5
228.020.004.000	ER 20	4	21	31,5
228.020.004.500	ER 20	4,5	21	31,5
228.020.005.000	ER 20	5	21	31,5
228.020.005.500	ER 20	5,5	21	31,5
228.020.006.000	ER 20	6	21	31,5
228.020.006.500	ER 20	6,5	21	31,5
228.020.007.000	ER 20	7	21	31,5
228.020.007.500	ER 20	7,5	21	31,5
228.020.008.000	ER 20	8	21	31,5
228.020.008.500	ER 20	8,5	21	31,5
228.020.009.000	ER 20	9	21	31,5
228.020.009.500	ER 20	9,5	21	31,5
228.020.010.000	ER 20	10	21	31,5
228.020.010.500	ER 20	10,5	21	31,5
228.020.011.000	ER 20	11	21	31,5
228.020.011.500	ER 20	11,5	21	31,5
228.020.012.000	ER 20	12	21	31,5
228.020.012.500	ER 20	12,5	21	31,5
228.020.013.000	ER 20	13	21	31,5

Präzisionszangen ≤ 0,005
auf Anfrage lieferbar
Precision collets ≤ 0,005



Spannzangen DIN 6499 B (ISO 15488 B) System ER

Collets DIN 6499 B (ISO 15488 B) ER system

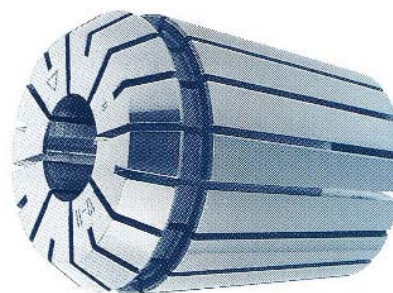
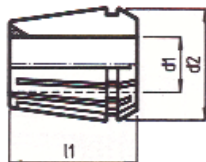

Bestell Nr. Code No.	Größe Size	d1 mm	d2 mm	l1 mm
-------------------------	---------------	----------	----------	----------

ER 25				
228.025.002.000	ER 25	2	26	34
228.025.002.500	ER 25	2,5	26	34
228.025.003.000	ER 25	3	26	34
228.025.003.500	ER 25	3,5	26	34
228.025.004.000	ER 25	4	26	34
228.025.004.500	ER 25	4,5	26	34
228.025.005.000	ER 25	5	26	34
228.025.005.500	ER 25	5,5	26	34
228.025.006.000	ER 25	6	26	34
228.025.006.500	ER 25	6,5	26	34
228.025.007.000	ER 25	7	26	34
228.025.007.500	ER 25	7,5	26	34
228.025.008.000	ER 25	8	26	34
228.025.008.500	ER 25	8,5	26	34
228.025.009.000	ER 25	9	26	34
228.025.009.500	ER 25	9,5	26	34
228.025.010.000	ER 25	10	26	34
228.025.010.500	ER 25	10,5	26	34
228.025.011.000	ER 25	11	26	34
228.025.011.500	ER 25	11,5	26	34
228.025.012.000	ER 25	12	26	34
228.025.012.500	ER 25	12,5	26	34
228.025.013.000	ER 25	13	26	34
228.025.013.500	ER 25	13,5	26	34
228.025.014.000	ER 25	14	26	34
228.025.014.500	ER 25	14,5	26	34
228.025.015.000	ER 25	15	26	34
228.025.015.500	ER 25	15,5	26	34
228.025.016.000	ER 25	16	26	34

Bestell Nr. Code No.	Größe Size	d1 mm	d2 mm	l1 mm
-------------------------	---------------	----------	----------	----------

ER 32				
228.032.002.000	ER 32	2	33	40
228.032.002.500	ER 32	2,5	33	40
228.032.003.000	ER 32	3	33	40
228.032.003.500	ER 32	3,5	33	40
228.032.004.000	ER 32	4	33	40
228.032.004.500	ER 32	4,5	33	40
228.032.005.000	ER 32	5	33	40
228.032.005.500	ER 32	5,5	33	40
228.032.006.000	ER 32	6	33	40
228.032.006.500	ER 32	6,5	33	40
228.032.007.000	ER 32	7	33	40
228.032.007.500	ER 32	7,5	33	40
228.032.008.000	ER 32	8	33	40
228.032.008.500	ER 32	8,5	33	40
228.032.009.000	ER 32	9	33	40
228.032.009.500	ER 32	9,5	33	40
228.032.010.000	ER 32	10	33	40
228.032.010.500	ER 32	10,5	33	40
228.032.011.000	ER 32	11	33	40
228.032.011.500	ER 32	11,5	33	40
228.032.012.000	ER 32	12	33	40
228.032.012.500	ER 32	12,5	33	40
228.032.013.000	ER 32	13	33	40
228.032.013.500	ER 32	13,5	33	40
228.032.014.000	ER 32	14	33	40
228.032.014.500	ER 32	14,5	33	40
228.032.015.000	ER 32	15	33	40
228.032.015.500	ER 32	15,5	33	40
228.032.016.000	ER 32	16	33	40
228.032.016.500	ER 32	16,5	33	40
228.032.017.000	ER 32	17	33	40
228.032.017.500	ER 32	17,5	33	40
228.032.018.000	ER 32	18	33	40
228.032.018.500	ER 32	18,5	33	40
228.032.019.000	ER 32	19	33	40
228.032.019.500	ER 32	19,5	33	40
228.032.020.000	ER 32	20	33	40

Präzisionszangen ≤ 0,005
auf Anfrage lieferbar
Precision collets ≤ 0,005



Spannzangen DIN 6499 B (ISO 15488 B) System ER

Collets DIN 6499 B (ISO 15488 B) ER system

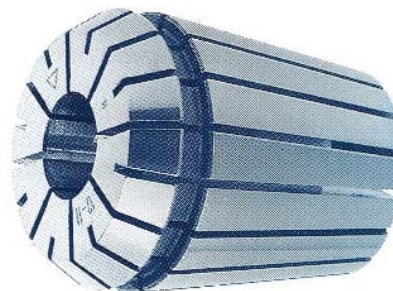
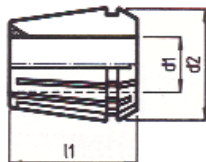

Bestell Nr. Code No.	Größe Size	d1 mm	d2 mm	l1 mm
-------------------------	---------------	----------	----------	----------

ER 40				
228.040.003.000	ER 40	3	41	46
228.040.004.000	ER 40	4	41	46
228.040.005.000	ER 40	5	41	46
228.040.006.000	ER 40	6	41	46
228.040.007.000	ER 40	7	41	46
228.040.008.000	ER 40	8	41	46
228.040.009.000	ER 40	9	41	46
228.040.010.000	ER 40	10	41	46
228.040.011.000	ER 40	11	41	46
228.040.012.000	ER 40	12	41	46
228.040.013.000	ER 40	13	41	46
228.040.014.000	ER 40	14	41	46

Bestell Nr. Code No.	Größe Size	d1 mm	d2 mm	l1 mm
-------------------------	---------------	----------	----------	----------

ER 40				
228.040.015.000	ER 40	15	41	46
228.040.016.000	ER 40	16	41	46
228.040.017.000	ER 40	17	41	46
228.040.018.000	ER 40	18	41	46
228.040.019.000	ER 40	19	41	46
228.040.020.000	ER 40	20	41	46
228.040.021.000	ER 40	21	41	46
228.040.022.000	ER 40	22	41	46
228.040.023.000	ER 40	23	41	46
228.040.024.000	ER 40	24	41	46
228.040.025.000	ER 40	25	41	46
228.040.026.000	ER 40	26	41	46

Spannzangensätze DIN 6499 B (ISO 15488 B) System ER

Collets sets DIN 6499 B (ISO 15488 B) ER system



Bestell Nr. Code No.	Größe Size	Stück Qty	Abmessungen Size
-------------------------	---------------	--------------	---------------------

228.008.001.005	ER8	9	1-1,5-2-2,5-3-3,5-4-4,5-5
228.011.001.007	ER 11	13	1-1,5-2-2,5-3-3,5-4-4,5-5-5,5-6-6,5-7
228.016.001.010	ER 16	10	1-2-3-4-5-6-7-8-9-10
228.020.002.013	ER 20	12	2-3-4-5-6-7-8-9-10-11-12-13
228.025.002.016	ER 25	15	2-3-4-5-6-7-8-9-10-11-12-13-14-15-16
228.032.003.020	ER 32	18	3-4-5-6-7-8-9-10-11-12-13-14-15-16-17-18-19-20
228.040.004.026	ER 40	23	4-5-6-7-8-9-10-11-12-13-14-15-16-17-18-19-20-21-22-23-24-25-26



Spannzangen mit Abdichtung für IK DIN 6499 B (ISO 15488 B) System ER

Collets sealed with seal for IC DIN 6499 B (ISO 15488 B) ER system

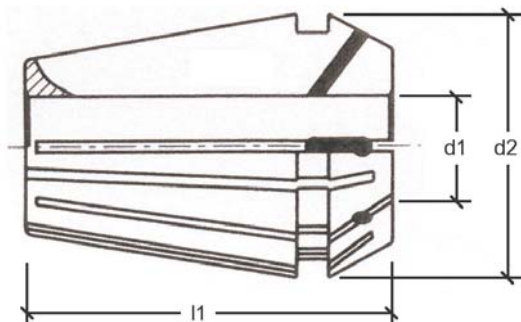

Bestell Nr. Code No.	Größe Size	d1 mm	d2 mm	l1 mm
-------------------------	---------------	----------	----------	----------

ER 16				
228.016.003.A00	ER 16	3	17	27,5
228.016.004.A00	ER 16	4	17	27,5
228.016.005.A00	ER 16	5	17	27,5
228.016.006.A00	ER 16	6	17	27,5
228.016.007.A00	ER 16	7	17	27,5
228.016.008.A00	ER 16	8	17	27,5
228.016.009.A00	ER 16	9	17	27,5
228.016.010.A00	ER 16	10	17	27,5

ER20				
228.020.003.A00	ER 20	3	21	31,5
228.020.004.A00	ER 20	4	21	31,5
228.020.005.A00	ER 20	5	21	31,5
228.020.006.A00	ER 20	6	21	31,5
228.020.007.A00	ER 20	7	21	31,5
228.020.008.A00	ER 20	8	21	31,5
228.020.009.A00	ER 20	9	21	31,5
228.020.010.A00	ER 20	10	21	31,5
228.020.011.A00	ER 20	11	21	31,5
228.020.012.A00	ER 20	12	21	31,5
228.020.013.A00	ER 20	13	21	31,5

ER 25				
228.025.003.A00	ER 25	3	26	34
228.025.004.A00	ER 25	4	26	34
228.025.005.A00	ER 25	5	26	34
228.025.006.A00	ER 25	6	26	34
228.025.007.A00	ER 25	7	26	34
228.025.008.A00	ER 25	8	26	34
228.025.009.A00	ER 25	9	26	34
228.025.010.A00	ER 25	10	26	34
228.025.011.A00	ER 25	11	26	34
228.025.012.A00	ER 25	12	26	34
228.025.013.A00	ER 25	13	26	34
228.025.014.A00	ER 25	14	26	34
228.025.015.A00	ER 25	15	26	34
228.025.016.A00	ER 25	16	26	34

Bestell Nr. Code No.	Größe Size	d1 mm	d2 mm	l1 mm
-------------------------	---------------	----------	----------	----------

ER 32				
228.032.003.A00	ER 32	3	33	40
228.032.004.A00	ER 32	4	33	40
228.032.005.A00	ER 32	5	33	40
228.032.006.A00	ER 32	6	33	40
228.032.007.A00	ER 32	7	33	40
228.032.008.A00	ER 32	8	33	40
228.032.009.A00	ER 32	9	33	40
228.032.010.A00	ER 32	10	33	40
228.032.011.A00	ER 32	11	33	40
228.032.012.A00	ER 32	12	33	40
228.032.013.A00	ER 32	13	33	40
228.032.014.A00	ER 32	14	33	40
228.032.015.A00	ER 32	15	33	40
228.032.016.A00	ER 32	16	33	40
228.032.017.A00	ER 32	17	33	40
228.032.018.A00	ER 32	18	33	40
228.032.019.A00	ER 32	19	33	40
228.032.020.A00	ER 32	20	33	40

ER 40				
228.040.003.A00	ER 40	3	41	46
228.040.004.A00	ER 40	4	41	46
228.040.005.A00	ER 40	5	41	46
228.040.006.A00	ER 40	6	41	46
228.040.007.A00	ER 40	7	41	46
228.040.008.A00	ER 40	8	41	46
228.040.009.A00	ER 40	9	41	46
228.040.010.A00	ER 40	10	41	46
228.040.011.A00	ER 40	11	41	46
228.040.012.A00	ER 40	12	41	46
228.040.013.A00	ER 40	13	41	46
228.040.014.A00	ER 40	14	41	46
228.040.015.A00	ER 40	15	41	46
228.040.016.A00	ER 40	16	41	46
228.040.017.A00	ER 40	17	41	46
228.040.018.A00	ER 40	18	41	46
228.040.019.A00	ER 40	19	41	46
228.040.020.A00	ER 40	20	41	46
228.040.021.A00	ER 40	21	41	46
228.040.022.A00	ER 40	22	41	46
228.040.023.A00	ER 40	23	41	46
228.040.024.A00	ER 40	24	41	46
228.040.025.A00	ER 40	25	41	46
228.040.026.A00	ER 40	26	41	46



Spannzangen mit Innenvierkant DIN 6499 A (ISO 15488 A) System ER für Gewindebohrer

Collets with square locking drive DIN 6499 A (ISO 15488 A) ER system for taps

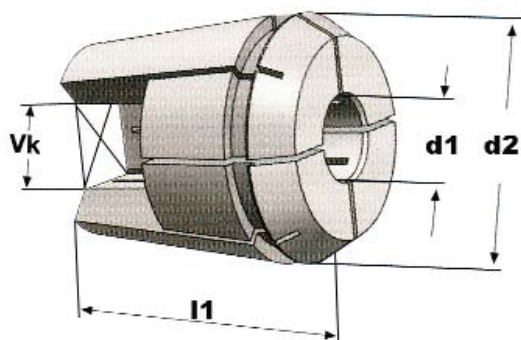

Bestell Nr. Code No.	Größe Size	d1 mm	VK mm	d2 mm	l1 mm
-------------------------	---------------	----------	----------	----------	----------

ER 16					
228.G16.035.027	ER 16	3,5	2,7	17	27,5
228.G16.040.030	ER 16	4	3	17	27,5
228.G16.045.034	ER 16	4,5	3,4	17	27,5
228.G16.050.040	ER 16	5	4	17	27,5
228.G16.055.043	ER 16	5,5	4,3	17	27,5
228.G16.060.049	ER 16	6	4,9	17	27,5
228.G16.070.055	ER 16	7	5,5	17	27,5
228.G16.090.070	ER 16	9	7	17	27,5
228.G16.100.080	ER 16	10	8	17	27,5

ER20					
228.G20.035.027	ER 20	3,5	2,7	21	31,5
228.G20.040.030	ER 20	4	3	21	31,5
228.G20.045.034	ER 20	4,5	3,4	21	31,5
228.G20.055.043	ER 20	5,5	4,3	21	31,5
228.G20.060.049	ER 20	6	4,9	21	31,5
228.G20.070.055	ER 20	7	5,5	21	31,5
228.G20.080.062	ER 20	8	6,2	21	31,5
228.G20.090.070	ER 20	9	7	21	31,5
228.G20.100.080	ER 20	11	8	21	31,5
228.G20.110.090	ER 20	11	9	21	31,5
228.G20.120.090	ER 20	12	9	21	31,5

ER 25					
228.G25.035.027	ER 25	3,5	2,7	26	34
228.G25.040.030	ER 25	4	3	26	34
228.G25.045.034	ER 25	4,5	3,4	26	34
228.G25.050.040	ER 25	5	4	26	34
228.G25.055.043	ER 25	5,5	4,3	26	34
228.G25.060.049	ER 25	6	4,9	26	34
228.G25.070.055	ER 25	7	5,5	26	34
228.G25.080.062	ER 25	8	6,2	26	34
228.G25.090.070	ER 25	9	7	26	34
228.G25.100.080	ER 25	10	8	26	34
228.G25.110.090	ER 25	11	9	26	34
228.G25.120.090	ER 25	12	9	26	34
228.G25.140.110	ER 25	14	11	26	34
228.G25.160.120	ER 25	16	12	26	34

Bestell Nr. Code No.	Größe Size	d1 mm	VK mm	d2 mm	l1 mm
-------------------------	---------------	----------	----------	----------	----------

ER 32					
228.G32.040.030	ER 32	4	3	33	40
228.G32.045.034	ER 32	4,5	3,4	33	40
228.G32.050.040	ER 32	5	4	33	40
228.G32.055.043	ER 32	5,5	4,3	33	40
228.G32.060.049	ER 32	6	4,9	33	40
228.G32.070.055	ER 32	7	5,5	33	40
228.G32.080.062	ER 32	8	6,2	33	40
228.G32.090.070	ER 32	9	7	33	40
228.G32.100.080	ER 32	10	8	33	40
228.G32.110.090	ER 32	11	9	33	40
228.G32.120.090	ER 32	12	9	33	40
228.G32.140.110	ER 32	14	11	33	40
228.G32.160.125	ER 32	16	12	33	40
228.G32.180.145	ER 32	18	14,5	33	40
228.G32.200.160	ER 32	20	16	33	40

ER 40					
228.G40.060.049	ER 40	6	4,9	41	46
228.G40.070.055	ER 40	7	5,5	41	46
228.G40.080.062	ER 40	8	6,2	41	46
228.G40.090.070	ER 40	9	7	41	46
228.G40.100.080	ER 40	10	8	41	46
228.G40.110.090	ER 40	11	9	41	46
228.G40.120.090	ER 40	12	9	41	46
228.G40.140.110	ER 40	14	11	41	46
228.G40.160.125	ER 40	16	12	41	46
228.G40.180.145	ER 40	18	14,5	41	46
228.G40.200.160	ER 40	20	16	41	46
228.G40.220.180	ER 40	22	18	41	46
228.G40.250.200	ER 40	25	20	41	46



Reduzierhülsen für Zangenkraftspannfutter

Reducing arbor for Great Power Collet chucks

Typ: A

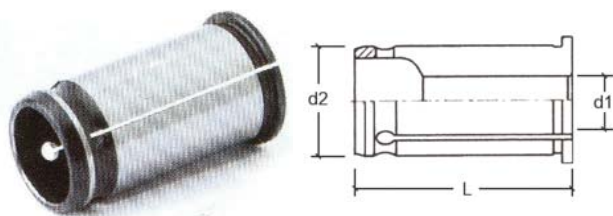

Typ: B

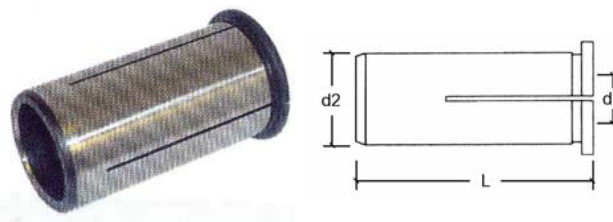

Typ: A

Bestell Nr. Code No.	d1 mm	d2 mm	L mm
229.A20.006.053	6	20	53
229.A20.007.053	7	20	53
229.A20.008.053	8	20	53
229.A20.010.053	10	20	53
229.A20.012.053	12	20	53
229.A20.014.053	14	20	53
229.A20.015.053	15	20	53
229.A20.016.053	16	20	53

Bestell Nr. Code No.	d1 mm	d2 mm	L mm
229.A32.006.065	6	32	65
229.A32.008.065	8	32	65
229.A32.010.065	10	32	65
229.A32.012.065	12	32	65
229.A32.014.065	14	32	65
229.A32.015.065	15	32	65
229.A32.016.065	16	32	65
229.A32.020.065	20	32	65
229.A32.025.065	25	32	65

Typ: B hermetisch abgedichtet

hermetically sealed

Bestell Nr. Code No.	d1 mm	d2 mm	L mm
229.B20.003.053	3	20	53
229.B20.004.053	4	20	53
229.B20.005.053	5	20	53
229.B20.006.053	6	20	53
229.B20.007.053	7	20	53
229.B20.008.053	8	20	53
229.B20.009.053	9	20	53
229.B20.010.053	10	20	53
229.B20.011.053	11	20	53
229.B20.012.053	12	20	53
229.B20.013.053	13	20	53
229.B20.014.053	14	20	53
229.B20.015.053	15	20	53
229.B20.016.053	16	20	53
229.B40.016.073	16	40	73
229.B40.020.073	20	40	73
229.B40.025.073	25	40	73
229.B40.032.073	32	40	73
229.B50.020.083	20	50	83
229.B50.025.083	25	50	83
229.B50.032.083	32	50	83
229.B50.040.083	40	50	83
229.B50.042.083	42	50	83

Bestell Nr. Code No.	d1 mm	d2 mm	L mm
229.B32.003.065	3	32	65
229.B32.004.065	4	32	65
229.B32.005.065	5	32	65
229.B32.006.065	6	32	65
229.B32.007.065	7	32	65
229.B32.008.065	8	32	65
229.B32.009.065	9	32	65
229.B32.010.065	10	32	65
229.B32.011.065	11	32	65
229.B32.012.065	12	32	65
229.B32.013.065	13	32	65
229.B32.014.065	14	32	65
229.B32.015.065	15	32	65
229.B32.016.065	16	32	65
229.B32.017.065	17	32	65
229.B32.018.065	18	32	65
229.B32.019.065	19	32	65
229.B32.020.065	20	32	65
229.B32.021.065	21	32	65
229.B32.022.065	22	32	65
229.B32.023.065	23	32	65
229.B32.024.065	24	32	65
229.B32.025.065	25	32	65
229.B32.026.065	26	32	65



Reduzierbüchsen für Hydrodehnspannfutter

Reducing arbor for hydraulic chucks

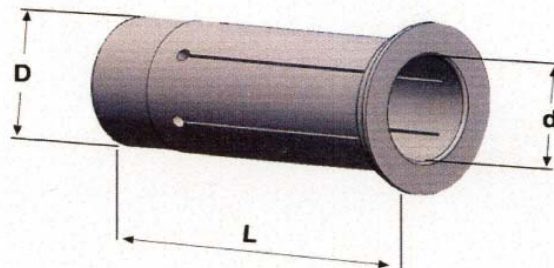

Bestell Nr. Code No.	D mm	d mm	L mm
231.012.003.046	12	3	46
231.012.004.046	12	4	46
231.012.005.046	12	5	46
231.012.006.046	12	6	46
231.012.008.046	12	8	46
231.020.003.052	20	3	52,5
231.020.004.052	20	4	52,5
231.020.005.052	20	5	52,5
231.020.006.052	20	6	52,5
231.020.008.052	20	8	52,5
231.020.010.052	20	10	52,5
231.020.012.052	20	12	52,5
231.020.014.052	20	14	52,5
231.020.016.052	20	16	52,5
231.032.006.063	32	6	63
231.032.008.063	32	8	63
231.032.010.063	32	10	63
231.032.012.063	32	12	63
231.032.014.063	32	14	63
231.032.016.063	32	16	63
231.032.020.063	32	20	63
231.032.025.063	32	25	63



Spannmutter DIN 6499 (ISO 15488) System ER

Clamping nuts DIN 6499 (ISO 15488) ER system

Standardausführung mit Exenterring, gewuchtet
standard type with eccentric ring, balanced



Bestell Nr. Code No.	Größe Size	D mm	L mm	SW mm	M
456.016.032.018	ER16	32	18	~	M22x1,5
456.020.035.019	ER20	35	19	~	M25x1,5
456.025.042.020	ER25	42	20	~	M32x1,5
456.032.050.022	ER32	50	22	~	M40x1,5
456.040.063.025	ER40	63	25	~	M50x1,5

gleitgelagerte Ausführung
sleeve-bearing version



Bestell Nr. Code No.	Größe Size	D mm	L mm	SW mm	M
456.016.032.G18	ER16	32	18	~	M22x1,5
456.025.042.G20	ER25	42	20	~	M32x1,5
456.032.050.G22	ER32	50	22	~	M40x1,5
456.040.063.G25	ER40	63	25	~	M50x1,5

Standardausführung mit Exenterring, gewuchtet
standard type with eccentric ring, balanced



Bestell Nr. Code No.	Größe Size	D mm	L mm	SW mm	M
456.611.019.012	ER11	19	12	17	M14x,075
456.616.028.018	ER16	28	18	25	M22x1,5
456.620.034.019	ER20	42	19	30	M25x1,5

gleitgelagerte Ausführung
sleeve-bearing version



Bestell Nr. Code No.	Größe Size	D mm	L mm	SW mm	M
456.616.028.G18	ER16	30	18	27	M22x1,5

Standardausführung mit Exenterring, gewuchtet TYP MINI
standard type with eccentric ring, balanced TYP MINI



Bestell Nr. Code No.	Größe Size	D mm	L mm	SW mm	M
456.M08.012.011	ER8	12	11	~	M10x0,75
456.M11.016.012	ER11	16	12	~	M13x0,75
456.M16.022.018	ER16	22	18	~	M19x1
456.M25.035.021	ER25	35	21	~	M30x1

Spannmutter Typ: OZ DIN 6388 D
kugelgelagerte Ausführung
Clamping nuts type: OZ DIN 6388 D
ball-bearing version



Bestell Nr. Code No.	Größe Size	D mm	L mm	SW mm	M
484.016.043.024	OZ16	43	24	~	M33x1,5
484.025.060.030	OZ25	60	30	~	M48x2
484.032.072.033	OZ32	72	33,5	~	M60x2,5



Spannmutter DIN 6499 (ISO 15488) System ER für Dichtscheiben

Clamping nuts DIN 6499 (ISO 15488) ER system for sealing discs

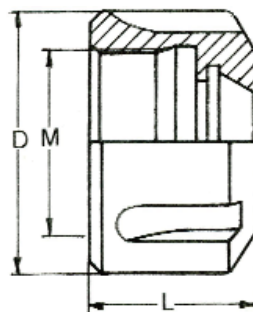
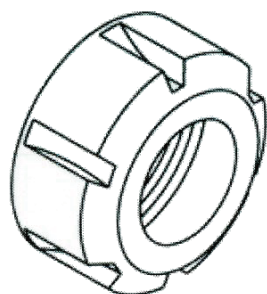

Bestell Nr. Code No.	Größe Size	D mm	L mm	M	Ausführung model
458.016.032.018	ER 16	32	18	M25x1,5	Standard
458.025.042.020	ER 25	42	20	M32x1,5	Standard
458.032.050.022	ER 32	50	22	M40x1,5	Standard
458.040.063.025	ER 40	63	25	M50x1,5	Standard

Dichtscheiben für ER Spannmutter

Sealing discs for ER clamping nuts



Bestell Nr. Code No.	Größe Size	d von -bis d from -to	Steigung step
457.016.XXX.XXX	ER 16	3,0-10,0mm	0,5mm
457.025.XXX.XXX	ER 25	3,0-16,0mm	0,5mm
457.032.XXX.XXX	ER 32	3,0-20,0mm	0,5mm
457.040.XXX.XXX	ER 40	3,0-26,0mm	0,5mm

Bestellbeispiel für A) ER16 4,0mm und B) ER32 11,5mm

Code für A= 457.016.004.000

Code für B= 457.032.011.500

Ordering example for A) ER16 4,0mm and B) ER32 11,5mm

Code for A= 457.016.004.000

Code for B= 457.032.011.500



Schnellwechsel-Einsätze ohne Überlastungskupplung

Quick change adaptors without safety clutch

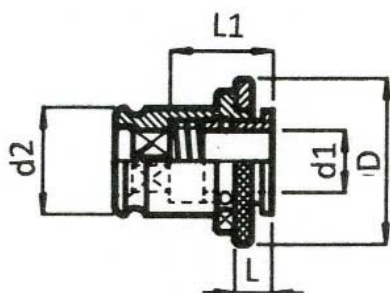

Bestell Nr. Code No.	Größe Size	D mm	d2 mm	d1 mm	V mm	L mm	L1 mm
331.019.028.021	1	30	19	2,8	2,1	7	17
331.019.035.027	1	30	19	3,5	2,7	7	17
331.019.040.030	1	30	19	4	3	7	17
331.019.045.034	1	30	19	4,5	3,4	7	17
331.019.060.049	1	30	19	6	4,9	7	17
331.019.050.040	1	30	19	5	4	7	17
331.019.070.055	1	30	19	7	5,5	7	17
331.019.080.062	1	30	19	8	6,2	7	17
331.019.090.070	1	30	19	9	7	7	17
331.019.100.080	1	30	19	10	8	7	17
331.019.110.090	1	30	19	11	9	7	17
331.031.060.049	2	48	31	6	4,9	11	30
331.031.070.055	2	48	31	7	5,5	11	30
331.031.080.062	2	48	31	8	6,2	11	30
331.031.090.070	2	48	31	9	7	11	30
331.031.100.080	2	48	31	10	8	11	30
331.031.110.090	2	48	31	11	9	11	30
331.031.120.090	2	48	31	12	9	11	30
331.031.140.110	2	48	31	14	11	11	30
331.031.160.120	2	48	31	16	12	11	30
331.031.180.145	2	48	31	18	14,5	11	30
331.048.110.090	3	70	48	11	9	14	44
331.048.120.090	3	70	48	12	9	14	44
331.048.140.110	3	70	48	14	11	14	44
331.048.160.120	3	70	48	16	12	14	44
331.048.180.145	3	70	48	18	14,5	14	44
331.048.200.160	3	70	48	20	16	14	44
331.048.220.180	3	70	48	22	18	14	44
331.048.250.200	3	70	48	25	20	14	44
331.048.280.220	3	70	48	28	22	14	44

für for				
DIN 371	DIN 376/374	DIN 353	DIN 2182	DIN 2183
M2-M2,5				
M3	M5		1/8"	
M3,5			5/32"	
M4	M6		7/32"	1/4"
M5-6	M8			
JIS-Norm				
	M10	R 1/8"	1/4"	3/8"
M8			5/16"	7/16"
	M12		3/8"	1/2"
M10				
	M14	R 1/4"		9/16"
M5-6				
	M8			
	M10	R 1/8"		3/8"
M8				7/16"
	M12			1/2"
M10				
	M14	R 1/4"		9/16"
	M16	R 3/8"		5/8"
	M18			11/16"
	M20	R 1/2"		13/16"
	M22-24	R 5/8"		7/8"-15/16"
M14				
	M16	R 1/4"		9/16"
	M18	R 3/8"		5/8"
	M20			11/16"
	M20	R 1/2"		13/16"
	M22-24	R 5/8"		7/8"-15/16"
	M27	R 3/4"		1"
	M30	R 7/8"		1.1/8"
	M33	R 1"		1.1/4"
	M36	R 1.1/8"		1.3/8"



Schnellwechsel-Einsätze mit Überlastungskupplung

Quick change adaptors with safety clutch

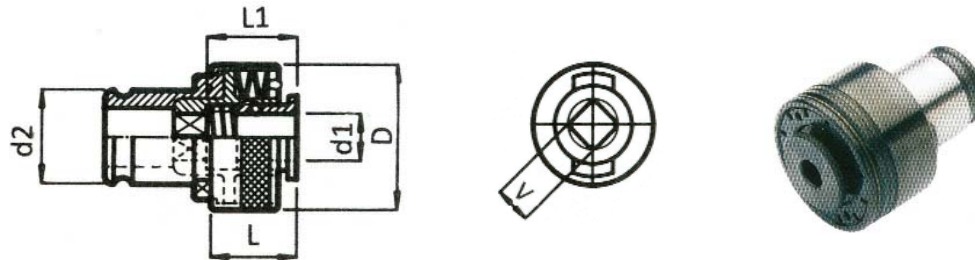

Bestell Nr. Code No.	Größe Size	D mm	d2 mm	d1 mm	V mm	L mm	L1 mm	für for				
								DIN 371	DIN 376/374	DIN 353	DIN 2182	DIN 2183
334.019.028.021	1	32	19	2,8	2,1	25	17	M2-M2,5				
334.019.035.027	1	32	19	3,5	2,7	25	17	M3	M5	1/8"		
334.019.040.030	1	32	19	4	3	25	17	M3,5	5/32"			
334.019.045.034	1	32	19	4,5	3,4	25	17	M4	M6	7/32" 1/4"		
334.A19.060.049	1	32	19	4,5	3,4	25	17	M5				
334.019.060.049	1	32	19	6	4,9	25	17	M6	M8			
334.019.070.055	1	32	19	7	5,5	25	17	M8	M10	R 1/8"	1/4"	3/8"
334.019.080.062	1	32	19	8	6,2	25	17	M8	5/16" 7/16"			
334.019.090.070	1	32	19	9	7	25	17	M10	M12	3/8" 1/2"		
334.019.100.080	1	32	19	10	8	25	17	M10				
334.019.110.090	1	32	19	11	9	25	17	M10	M14	R 1/4"	9/16"	
334.A31.060.049	2	50	31	6	4,9	34	30	M5				
334.031.060.049	2	50	31	6	4,9	34	30	M6	M8			
334.031.070.055	2	50	31	7	5,5	34	30	M8	M10	R 1/8"	3/8"	
334.031.080.062	2	50	31	8	6,2	34	30	M8	7/16"			
334.031.090.070	2	50	31	9	7	34	30	M10	M12	1/2"		
334.031.100.080	2	50	31	10	8	34	30	M10				
334.031.110.090	2	50	31	11	9	34	30	M10	M14	R 1/4"	9/16"	
334.031.120.090	2	50	31	12	9	34	30	M10	M16	R 3/8"	5/8"	
334.031.140.110	2	50	31	14	11	34	30	M10	M18	11/16"		
334.031.160.120	2	50	31	16	12	34	30	M10	M20	R 1/2"	13/16"	
334.031.180.145	2	50	31	18	14,5	34	30	M10	M22-24	R 5/8"	7/8"-15/16"	
334.048.110.090	3	72	48	11	9	44	44	M14	R 1/4"	9/16"		
334.048.120.090	3	72	48	12	9	44	44	M16	R 3/8"	5/8"		
334.048.140.110	3	72	48	14	11	44	44	M18	11/16"			
334.048.160.120	3	72	48	16	12	44	44	M20	R 1/2"	13/16"		
334.048.180.145	3	72	48	18	14,5	44	44	M22	R 5/8"	7/8"-15/16"		
334.A48.180.145	3	72	48	18	14,5	44	44	M24				
334.048.200.160	3	72	48	20	16	44	44	M27	R 3/4"	1"		
334.048.220.180	3	72	48	22	18	44	44	M30	R 7/8"	1.1/8"		
334.048.250.200	3	72	48	25	20	44	44	M33	R 1"	1.1/4"		
334.048.280.220	3	72	48	28	22	44	44	M36	R 1.1/8"	1.3/8"		



Kühlmittelübergabesatz

Coolant sleeve

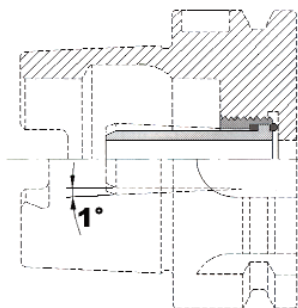
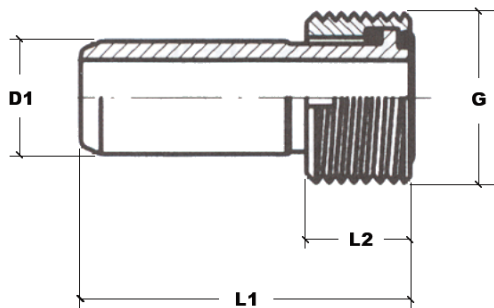

Bestell Nr. Code No.	HSK	D1 mm	G mm	L2 mm	L1 mm	
K32.M10.006	HSK32A	6	M10x1	5,5	26	S32.009
K40.M12.008	HSK40A	8	M12x1	7,5	29,1	S40.011
K50.M16.010	HSK50A	10	M16x1	9,5	32,7	S50.015
K63.M18.012	HSK63A	12	M18x1	11,5	36	S63.017
K80.M20.014	HSK80A	14	M20x1.5	13,5	39,6	S80.018
K10.M24.016	HSK100A	16	M24x1.5	15,5	43,6	S10.022

Inbusschlüssel

Wrench

Bestell Nr. Code No.	SW	A mm	L mm
920.000.SW4.100	4	70	100
920.000.SW5.100	5	90	100
920.000.SW6.100	6	90	100

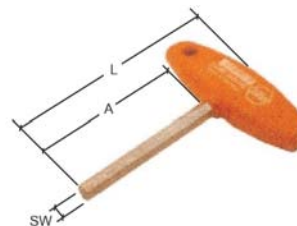

Austreiber

Drill drifts

Bestell Nr. Code No.	MK	T mm	B mm	L mm
940.012.140	MK1+2	5	20	140
940.003.190	MK3	7	25	190
940.004.225	MK4	10	30	225

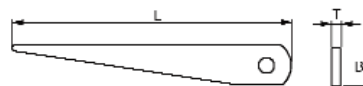

Paßfeder

Feather key

Bestell Nr. Code No.	M	h mm	b mm	L mm
941.016.020	M2x4	4	4	20
941.022.025	M3x5	6	6	25
941.027.025	M3x6	7	7	25
941.032.028	M3x6	8	7	28
941.040.032	M3x6	10	8	32

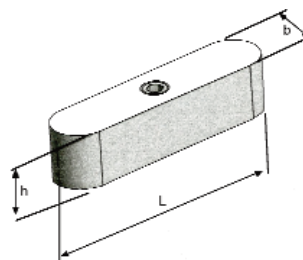

Spannschrauben für Weldon Spannfutter DIN 1835 B

Clamping screw for weldon chucks DIN 1835 B

Bestell Nr. Code No.	M	L mm	für Ø for Ø
432.006.M06.010	M6x1	10	6
432.008.M08.010	M8x1,25	10	8
432.010.M10.012	M10x1,5	12	10
432.012.M12.016	M12x1,75	16	12
432.014.M12.016	M12x1,75	16	14
432.016.M14.016	M14x2	16	16
432.018.M14.016	M14x2	16	18
432.020.M16.016	M16x2	16	20
432.025.M18.020	M18x2	20	25
432.032.M20.020	M20x2	20	32
432.040.M20.020	M20x2	20	40

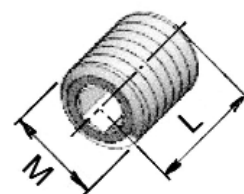

Anschlagschraube

Stop screw

Bestell Nr. Code No.	M	L mm	für Ø for Ø
433.006.M05.016	M5	16	6
433.008.M06.016	M6	16	8
433.010.M08.020	M8	20	10
433.012.M10.025	M10	25	12
433.014.M10.025	M10	25	14
433.016.M12.025	M12	25	16
433.018.M12.025	M12	25	18
433.020.M16.025	M16	25	20
433.025.M20.030	M20	30	25
433.032.M20.030	M20	30	32
433.040.M20.030	M20	30	40

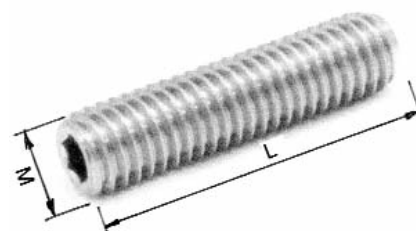

Längeneinstellschraube für Schrumpffutter (durchbohrt)

Length adjustment screw for Shrink fit holder (through hole)

Bestell Nr. Code No.	M	L mm	für Ø for Ø
434.006.M05.006	M5	6	6
434.008.M06.006	M6	6	8
434.010.M08.010	M8x1	10	10
434.012.M10.010	M10x1	10	12
434.014.M10.010	M10x1	10	14
434.016.M12.010	M12x1	10	16
434.018.M12.010	M12x1	10	18
434.020.M16.008	M16x1	8	20
434.025.M16.016	M16x1	16	25
434.032.M16.010	M16x1	10	32

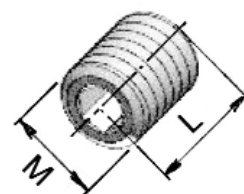



Fräseranzugsschraube DIN 6367

Drawn in bolt DIN 6367

Bestell Nr. Code No.	für Ø for Ø	M	D mm	K mm	L mm
422.016.M08.016	16	M8	20	6	16
422.022.M10.018	22	M10	28	7	18
422.027.M12.022	27	M12	35	8	22
422.032.M16.026	32	M16	42	9	26
422.040.M20.030	40	M20	52	10	30
422.050.M24.036	50	M24	63	12	36
422.060.M30.045	60	M30	75	14	45

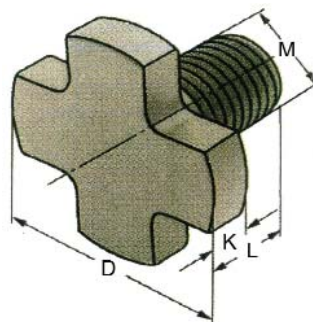

Fräseranzugsschraube DIN 6367 mit Kühlmittelzufuhr

Drawn in bolt DIN 6367 with coolant

Bestell Nr. Code No.	für Ø for Ø	M	D mm	K mm	L mm
421.016.M08.016	16	M8	20	9	16
421.022.M10.018	22	M10	28	7	18
421.027.M12.022	27	M12	35	8	22
421.032.M16.026	32	M16	42	9	26
421.040.M20.030	40	M20	52	10	30
421.050.M24.036	50	M24	63	12	36
421.060.M30.045	60	M30	75	14	45

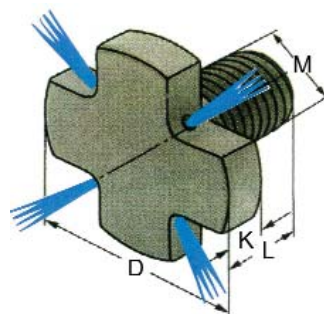

Mitnahmering DIN 6366

Clutch drive rings to DIN 6366

Bestell Nr. Code No.	d mm	D mm	L mm	b mm	L1 mm
424.016.032.010	16	32	10	8	5
424.022.040.012	22	40	12	10	5,6
424.027.048.012	27	48	12	12	6,3
424.032.058.014	32	58	14	14	7
424.040.070.014	40	70	14	16	8

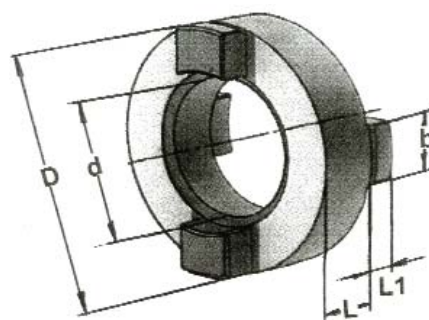

Mitnehmersteine

Drive key

Bestell Nr. Code No.	für Ø for Ø	h mm	b mm	L mm	Schraube DIN 912
426.016.008.010	16	8	10	9,8	M3x12
426.022.010.011	22	10	11	11,2	M4x12
426.027.012.014	27	12	14	12,6	M4x16
426.032.014.022	32	14	22	14	M5x16
426.040.016.023	40	16	23	16	M5x20
426.050.018.032	50	18	32	18	M6x20
426.060.254.265	60	25,4	26,5	25	M12x25

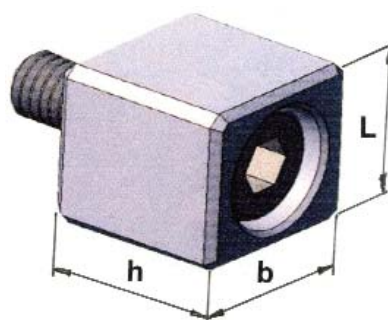



Spannschlüssel DIN 6368

Wrench DIN 6368

Bestell Nr. Code No.	D mm	für for
423.016.M08.000	16	M8
423.022.M10.000	22	M10
423.027.M12.000	27	M12
423.032.M16.000	32	M16
423.040.M20.000	40	M20
423.050.M24.000	50	M24
423.060.M30.000	60	M30

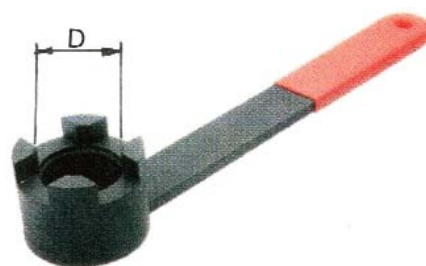

Spannschlüssel DIN 6368

Wrench DIN 6368

Bestell Nr. Code No.	Abmessung Size	D mm	SW mm
939.000.011.000	1-7 (ER11)	19	17
939.000.016.0SW	1-10 (ER16)	28	25
939.000.016.000	1-10 (ER16)	32	~
939.000.020.000	2-13 (ER20)	35	~
939.000.020.0SW	2-13 (ER20)	34	30
939.000.025.000	2-16 (ER25)	42	~
939.000.032.000	2-20 (ER32)	50	~
939.000.040.000	2-26 (ER40)	63	~



Spannschlüssel DIN 6368

Wrench DIN 6368

Bestell Nr. Code No.	Abmessung Size	D mm
938.000.008.000	1-5 (ER8)	12
938.000.011.000	1-7 (ER11)	16
938.000.016.000	1-10 (ER16)	22



Spannschlüssel DIN 6368

Wrench DIN 6368

Bestell Nr. Code No.	Abmessung Size	D mm
925.000.040.042	2-16 (OZ16)	40-42
925.000.058.062	2-25 (OZ25)	58-62
925.000.068.075	3-32 (OZ32)	68-75



Spannschlüssel DIN 6368

Wrench DIN 6368

Bestell Nr. Code No.
943.499.040.206

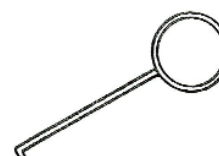



Schrumpfmaschinen (auf Anfrage)



Clarkson Präzisionswerkzeuge GmbH
Heinrich-Hertz-Str. 52
40699 Erkrath
Tel.: + 49 (0) 211 72 00 3-0 • Fax: + 49 (0) 211 72 00 333
email: info@clarkson.de

CLARKSON