



R-8 BRIDGPORT, STRAIGHT SHANKS, TOOLHOLDERS WITH
 AXIALLY ADJUSTABLE SHANK, STRAIGHT DIN 1835
*R-8 BRIDGPORT, CILÍNDRICO, PTHAS. CON
 REGULACION AXIAL DIN 6327, CILÍNDRICO DIN 1835*
 R8- BRIDGPORT, ZYL. SCHAFT, ADAPTER, ZYL.
 SCHAFT NACH DIN 1835

R-8 STRAIGHT
 DIN 6327/1835

FINE
 MACHINING

MODULAR

MORSE
 QUICK CHANGE

DIN 2080

POLYGONAL
 TAPER_LC6

BT_DUAL
 CONTACT

BT

DIN
 69871

HSK

	R-8 BRIDGPORT <i>R-8 BRIDGPORT</i> <i>R-8 BRIDGPORT</i>	229
	STRAIGHT SHANKS <i>MANGO CILINDRICO</i> <i>ZYLINDRISCHER SCHAFT</i>	235
	TOOLHOLDERS WITH AXIALLY ADJUSTABLE SHANKS <i>PHTAS. CON MANGO DE REGULACIÓN AXIAL</i> <i>ADAPTER MIT RADIAL EINSTELLBAREM SCHAFT</i>	241
	STRAIGHT DI 1835 <i>MANGO CILINDRICO DIN 1835</i> <i>ZYLINDRISCHER SCHAFT NACH DIN 1835</i>	245

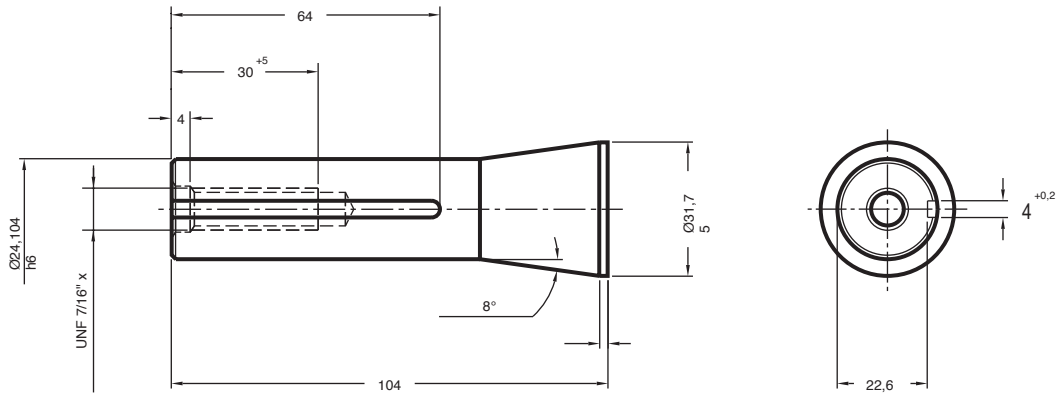

UNIVERSAL ARBORS
 PORTAFRESAS COMBINADO
 KOMBI-AUFSTECKFRÄSDORN 230



DRILL CHUCK ARBORS
 ADAPTADORES PARA PORTABROCAS
 BOHRFUTTERAUFNAHME 231



DIRECT COUPLING COLLETS
 PINZAS DE ACOPLAMIENTO DIRECTO
 DIREKTSPANNZANGE 231



REDUCING ADAPTERS TOMORSE
 REDUCTORES A MORSE
 REDUZIERUNG AUF MORSE 232



COLLET CHUCKS FOR DIN 6388 COLLETS
 PORTAPINZAS DIN 6388
 SPANNZANGENFUTTER TYP OZ (DIN 6388) 232



COLLET CHUCKS ER TYPE (DIN 6499)
 PORTAPINZAS TIPO ER (DIN 6499)
 SPANNZANGENFUTTER TYP ER (DIN 6499) 233



WELDON HOLDERS
 PORTAFRESAS WELDON
 FLÄCHENSPANNFUTTER WELDON 234



SHORT DRILL CHUCKS
 PORTABROCAS INTEGRAL
 KURZBOHRFUTTER 234

Material

Case-hardening alloy steel.
 Case-hardened and tempered.
 Minium strength in core 880 N/mm²
 Surface hardness HRC 57 ÷ 60

Material

Acero aleado de cementación.
 Cementado y templado.
 Resistencia mínima al núcleo 880 N/mm²
 Dureza superficial HRC 57 ÷ 60

Material

Hochlegierter Stahl
 Einsatzgehärtet
 Zugfestigkeit im Kern: mind. 880 N/mm²
 Oberflächenhärte: HRC 57-60

UNIVERSAL ARBORS
PORTAFRESAS COMBINADO
KOMBI-AUFSTECKFRÄSDORN



001 49 02 ...

For milling cutters with longitudinal or driving slot DIN 138.
 Para fresas con chavetero longitudinal o transversal DIN 138.
 Zur Aufnahme von Fräsern mit Längsnut oder Fräsern mit Quernut nach DIN 138.

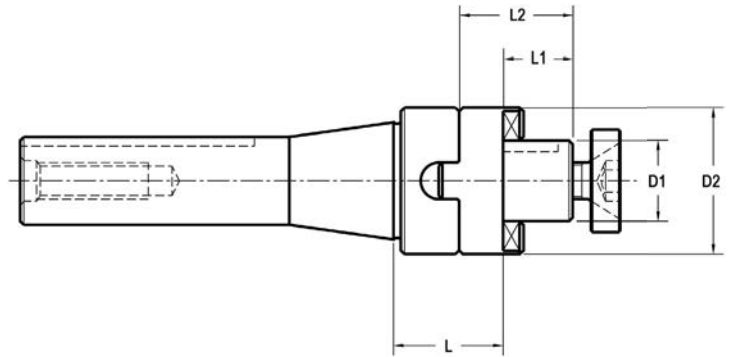

D1	L	L1	L2	D2	COD.	Availability Disponibilidad Verfügbarkeit
27	30	21	33	48	001 49 02 01 50	■
32	30	24	38	58	001 49 02 01 60	■

Circular deviation between K and D1 ≤ 0,008

Desviación circular entre K y D1 ≤ 0,008

Rundlaufabweichung zwischen K und D1 ≤ 0,008

ACCESSORIES INCLUDED
ACCESORIOS INCLUIDOS
ZUBEHÖR ENTHÄLT



D ₁	001 99 02 01 30	001 99 01 22 30	001 99 01 12 30
16	001 99 02 01 40	001 99 01 22 40	001 99 01 12 40
22	001 99 02 01 50	001 99 01 22 50	001 99 01 12 50
27	001 99 02 01 60	001 99 01 22 60	001 99 01 12 60
32	001 99 02 01 70	001 99 01 22 70	001 99 01 12 70
40	001 99 02 01 80	001 99 01 22 80	001 99 01 12 80
50			

OPTIONAL ACCESSORIES
ACCESORIOS OPCIONALES
OPTIONALES ZUBEHÖR

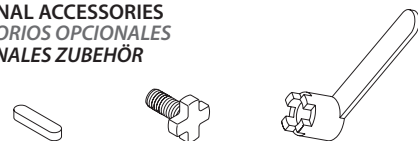

D ₁	001 99 03 02 30	001 99 01 01 30	001 99 04 01 30
16	001 99 03 02 40	001 99 01 01 40	001 99 04 01 40
22	001 99 03 02 50	001 99 01 01 50	001 99 04 01 50
27	001 99 03 02 60	001 99 01 01 60	001 99 04 01 60
32	001 99 03 02 70	001 99 01 01 70	001 99 04 01 70
40	001 99 03 02 80	001 99 01 01 80	001 99 04 01 80
50			

DRILL CHUCK ADAPTERS
ADAPTADOR DE PROTABROCAS
BOHRFUTTERAUFNAHME

001 49 50 ...



For DIN 238 or JACOBS.
 Para DIN 238 o JACOBS.
 Für DIN 238 oder System Jacobs

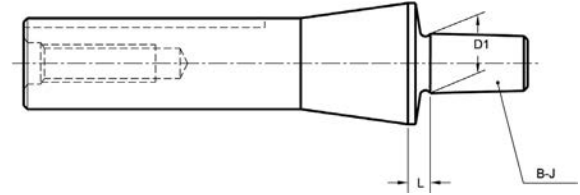

B-J	L	D1	COD.	Availability Disponibilidad Verfügbarkeit
B.12	8	12,06	001 49 50 01 01	<input type="checkbox"/>
B.16	8	15,73	001 49 50 01 02	<input type="checkbox"/>
B.18	8	17,78	001 49 50 01 03	<input type="checkbox"/>
J.2	8	14,19	001 49 50 01 13	<input type="checkbox"/>
J.3	8	20,59	001 49 50 01 15	<input type="checkbox"/>
J.33	8	15,85	001 49 50 01 19	<input type="checkbox"/>
J.6	8	17,17	001 49 50 01 18	<input type="checkbox"/>

Circular deviation between K and D1 ≤ 0,008

Desviación circular entre K y D1 ≤ 0,008

Rundlaufabweichung zwischen K und D1 ≤ 0,008

DIRECT COUPLING COLLETS
PINZAS DE ACOPLAMIENTO DIRECTO
SPANNZANGE

002 55 01 ...



R-8 Bridgeport

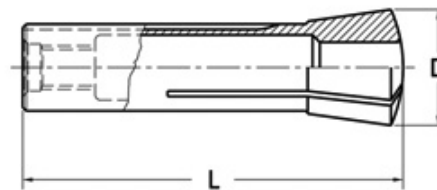

COD.	D	L	D1	Availability Disponibilidad Verfügbarkeit
002 55 01	31,75	105	3-4-8-10-11-12-13-14-15-16-17-18	<input type="checkbox"/>

- Material: Tempered spring steel.

- Hardness: HRC 56 – 58

- To order: COD. + D1. Example: 002 55 01/04

- Material: Acero de muelles templado.

- Dureza: HRC 56 – 58

- Para suministro: COD. + D1. Ejemplo: 002 55 01/04

- Werkstoff: Federstahl

- Oberflächenhärte: HRC 56-58

- Für Bestellung gem. COD. + D1. Beispiel: 002 55 01/04

HSK
 DIN 69871
 BT
 BT_DUAL CONTACT
 POLYGONAL TAPER_LC6
 DIN 2080
 MORSE QUICK CHANGE
 MODULAR
 FINE MACHINING
 R-8 STRAIGHT DIN 6327/1835

REDUCING ADAPTERS TO MORSE
REDUCTORES A MORSE
REDUZIERUNG FÜR MK



003 49 11 ...

For tanged Morse taper tools DIN 228-B.
 Para herramientas con lengüeta DIN 228-B.
 Für MK- Werkzeuge nach DIN 228-B.

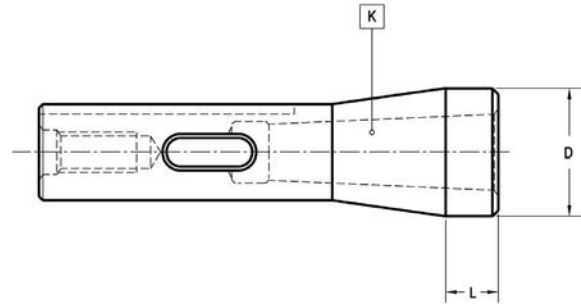

K	D	L	COD.	Availability Disponibilidad Verfügbarkeit
M1	32	13	003 49 11 01 20	■
M2	32	13	003 49 11 01 30	□
M3	38	71	003 49 11 01 40	■

RELATIONATED ELEMENTS
 ELEMENTOS RELACIONADOS
 VERWANDTE ARTIKEL

Page: 181

Circular deviation between R-8 taper and $K \leq 0,008$
 Desviación circular entre el cono exterior y $K \leq 0,008$
 Rundlaufabweichung zwischen K und $D1 \leq 0,008$



003 02 11 ...

COLLET CHUCKS FOR DIN 6388 COLLETS
PORTAPINZAS PARA PINZAS DIN 6388
SPANNZANGENFUTTER TYP OZ (DIN 6388)



004 49 01 ...

For tools with cylindrical straight shank DIN 1835-A or threaded cylindrical shank DIN 1835-D.
 Para herramientas con mango cilíndrico liso DIN 1835-A o cilíndrico roscado DIN 1835-D.
 Für Werkzeuge mit zylindrischem Schaft nach DIN 1835-A oder DIN 1835-D.

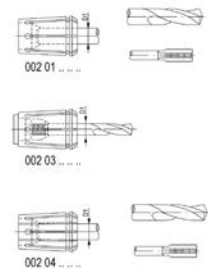
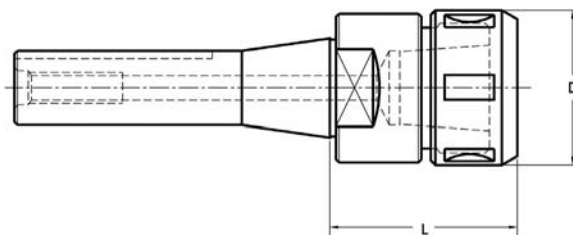

D1 máx.	L	D	COD.	Availability Disponibilidad Verfügbarkeit
25	70	60	004 49 01 01 05	■

RELATIONATED ELEMENTS
 ELEMENTOS RELACIONADOS
 VERWANDTE ARTIKEL

Page: 250



002 01 002 03 002 04 002 19

ACCESSORIES INCLUDED: Bearing nut
 ACCESORIOS INCLUIDOS: Tuerca con rodamiento
 ZUBEHÖR ENTHÄLT: Kugelgelagerte Spannmutter



D1max
 25 004 99 01 02 05

OPTIONAL ACCESSORIES
 ACCESORIOS OPCIONALES
 OPTIONALES ZUBEHÖR



D1max
 25 004 99 04 09 11

COLLET CHUCKS ER TYPE (DIN 6499)
PORTAPINZAS TIPO ER (DIN 6499)
SPANNZANGENFUTTER TYP ER (DIN 6499)



004 49 06 ...

For tools with cylindrical straight shank DIN 1835-A.
 Para herramientas con mango cilíndrico liso DIN 1835-A.
 Für Werkzeuge mit zylindrischem Schaft nach DIN 1835-A.

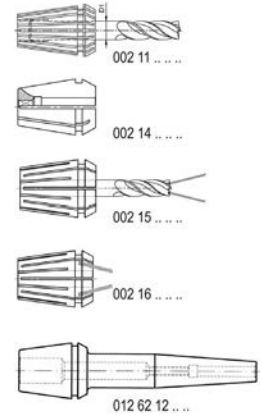
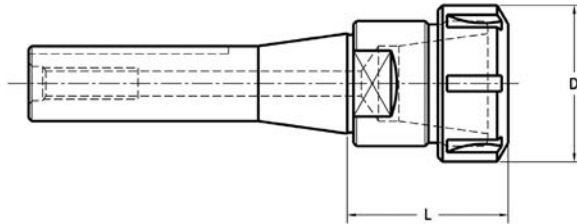

SIZE	D1 máx.	L	D	COD.	Availability Disponibilidad Verfügbarkeit
(ER32)	20	58	50	004 49 06 01 06	■

RELATIONATED ELEMENTS Page: 250
ELEMENTOS RELACIONADOS
VERWANDTE ARTIKEL

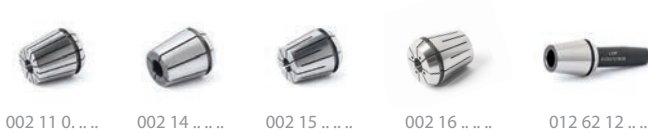

ACCESSORIES INCLUDED
ACCESORIOS INCLUIDOS
ZUBEHÖR ENTHÄLT

Conventional
Convencional
Standardausführung

Bearing shell nut
Con casquillo giratorio
Kugellagerte Ausführung

Notch free
Lisa
Nutenlose Mutter



OPTIONAL ACCESSORIES
ACCESORIOS OPCIONALES
OPTIONALES ZUBEHÖR



HSK
 DIN 69871
 BT
 BT_DUAL CONTACT
 POLYGONAL TAPER_LC6
 DIN 2080
 MORSE QUICK CHANGE
 MODULAR
 FINE MACHINING
 R-8 STRAIGHT DIN 63 27/1835

WELDON HOLDERS
PORTAFRESAS WELDON
FLÄCHENSPIANNFUTTER WELDON



012 49 01 ...

For end mills with shank DIN 1835-B - DIN 6535 HB.
 Para fresas con mango cilíndrico con encaste DIN 1835 Forma B y DIN 6535 Forma HB.
 Für Werkzeuge mit zylindrischem Schaft nach DIN 1835-B bzw. DIN 6535 HB.

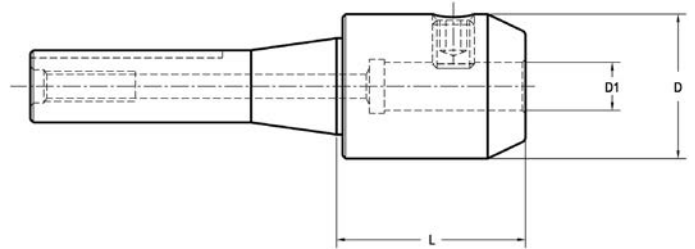

D1	D	L	COD.	Availability Disponibilidad Verfügbarkeit	
6	25	30	012 49 01 11 06	<input type="checkbox"/>	301 01 05 06 10
8	32	30	012 49 01 11 08	<input type="checkbox"/>	301 01 05 08 10
10	32	30	012 49 01 11 10	<input type="checkbox"/>	301 01 05 10 12
12	32	30	012 49 01 11 12	<input type="checkbox"/>	301 01 05 12 16
14	44	40	012 49 01 11 14	<input type="checkbox"/>	301 01 05 12 16
16	48	65	012 49 01 11 16	<input type="checkbox"/>	301 01 05 14 16
18	50	65	012 49 01 11 18	<input type="checkbox"/>	301 01 05 14 16

Circular deviation between K and D1 ≤ 0,005

Desviación circular entre K y D1 ≤ 0,005

Rundlaufabweichung zwischen K und D1 ≤ 0,005

SHORT DRILL CHUCKS
PORTABROCAS INTEGRAL
KURZBOHRFUTTER



012 49 09 ...

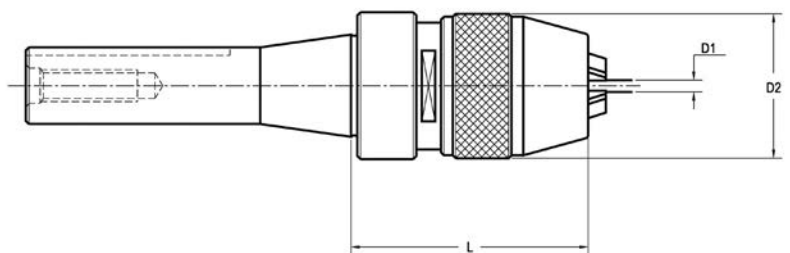

D1	L	D2	COD.	Availability Disponibilidad Verfügbarkeit			
0-8	65	36	012 49 09 11 08	<input type="checkbox"/>	351 02 60 00 08	351 02 61 00 08	020 99 03 00 08



D h6

16

20

25

32

40

50



UNIVERSAL ARBORS
 PORTAFRESAS COMBINADO
 KOMBI-AUFSTECKFRÄSDORN

236



SHORT DRILL CHUCKS
 PORTABROCAS INTEGRAL
 KURZBOHRFUTTER

238



REDUCING ADAPTERS TO MORSE
 REDUCTORES A MORSE
 REDUZIERUNG FÜR MK

236



SHRINK FIT EXTENSIONS
 PROLONGADOR DE CONTRACCIÓN TÉRMICA
 VERLÄNGERUNGEN FÜR SCHRUMPFUTTER

239



EXTENSION COLLET CHUCKS DIN 6499 (ER TYPE)
 PORTAPINZAS DE MANGO CILÍNDRICO DIN 6499 (TIPO ER)
 SPANNZANGENFUTTER TYP ER (DIN 6499)

237



FRONT CONTACT CYLINDRICAL EXTENSIONS FOR SCREW-IN-TOOLS
 PROLONGADORES DE MANGO CILÍNDRICO PARA MANGOS
 ROSCADOS CON APOYO FRONTAL
 VERLÄNGERUNGEN FÜR EINSCHRAUBFRÄSER

240

Material

Case-hardening alloy steel.
 Case-hardened and tempered.
 Minimum strength in core 880 N/mm²
 Surface hardness HRC 57 ÷ 60

Material

Acero aleado de cementación.
 Cementado y templado.
 Resistencia mínima al núcleo 880 N/mm²
 Dureza superficial HRC 57 ÷ 60

Material

Hochlegierter Stahl
 Einsatzgehärtet
 Zugfestigkeit im Kern: mind. 880 N/mm²
 Oberflächenhärte: HRC 57-60

UNIVERSAL ARBORS
PORTAFRESAS COMBINADO
KOMBI-AUFSTECKFRÄSDORN



001 50 02 ...

For milling cutters with longitudinal or driving slot DIN 138.
 Para fresas con chavetero longitudinal o transversal DIN 138.
 Zur Aufnahme von Fräsern mit Längsnut oder Fräsern mit Quernut nach DIN 138.

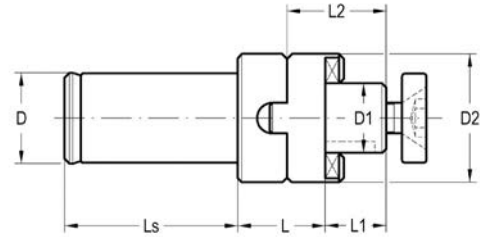

D h5	D1 h6	L	L1	L2	Ls	D2	COD.	Availability Disponibilidad Verfügbarkeit
32	16	25	17	27	60	32	001 50 02 06 30	■
32	22	25	19	31	60	40	001 50 02 06 40	■
32	27	28	21	33	60	48	001 50 02 06 50	■
32	32	30	24	38	60	58	001 50 02 06 60	■

ACCESSORIES INCLUDED
ACCESORIOS INCLUIDOS
ZUBEHÖR ENTHÄLT

D ₁			
16	001 99 02 01 30	001 99 01 22 30	001 99 01 12 30
22	001 99 02 01 40	001 99 01 22 40	001 99 01 12 40
27	001 99 02 01 50	001 99 01 22 50	001 99 01 12 50
32	001 99 02 01 60	001 99 01 22 60	001 99 01 12 60

OPTIONAL ACCESSORIES
ACCESORIOS OPCIONALES
OPCIONALES ZUBEHÖR

D ₁			
16	001 99 03 02 30	001 99 01 01 30	001 99 04 01 30
22	001 99 03 02 40	001 99 01 01 40	001 99 04 01 40
27	001 99 03 02 50	001 99 01 01 50	001 99 04 01 50
32	001 99 03 02 60	001 99 01 01 60	001 99 04 01 60

REDUCING ADAPTERS
REDUCTORES A MORSE
REDUZIERUNG FÜR MK



003 50 12 ...

For tapered Morse taper tools DIN 228-B or Morse taper tools with thread DIN 228-A.
 Para herramientas con rosca de tiro DIN 228-B.
 Für MK- Werkzeuge nach DIN 228-B

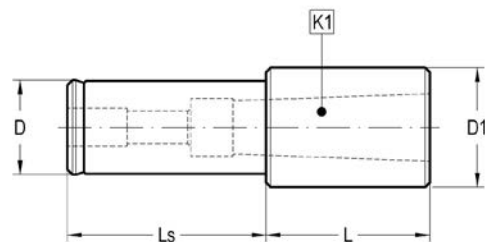

D h5	D1	K1	L	Ls	COD.	Availability Disponibilidad Verfügbarkeit
20	25	1	10	50	003 50 12 04 20	■
20	25	2	22	50	003 50 12 04 30	■
32	37	2	10	62	003 50 12 06 30	■
32	37	3	29	62	003 50 12 06 40	■

EXTENSION COLLET CHUCKS DIN 6499 (ER TYPE)
PORTAPINZAS DE MANGO CILÍNDRICO DIN 6499 (TIPO ER)
SPANNZANGENFUTTER TYP ER (DIN 6499) VERLÄNGERUNG



004 50 06 ...

For tools with cylindrical straight shank *DIN 1835-A*.
 Para herramientas con mango cilíndrico liso *DIN 1835-A*.
 Für Werkzeuge mit zylindrischem Schaft nach *DIN 1835-A*.

DIN 6499

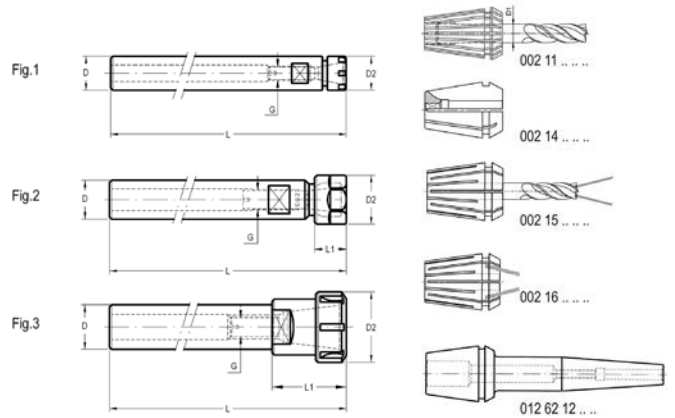

FIG.	D	SIZE	D1	D2	L	L1	G	COD.	Availability Disponibilidad Verfügbarkeit	
1	16	(ER11) Mini	0,5 - 7	16	160	-	M-8	004 50 06 12 12	■	301 01 02 08 30
2	16	(ER11)	0,5 - 7	19	160	-	M-8	004 50 06 12 02	■	301 01 02 08 30
2	20	(ER16)	0,5 - 10	28	80	-	M-10	004 50 06 03 03	■	301 01 02 10 30
1	20	(ER16) Mini	0,5 - 10	22	175	-	M-10	004 50 06 13 13	■	301 01 02 10 30
3	25	(ER16)	0,5 - 10	28	180	17	M-10	004 50 06 15 03	■	301 01 02 10 30
3	20	(ER25)	1 - 16	42	100	50	M-12	004 50 06 03 05	■	301 01 02 12 30
3	25	(ER25)	1 - 16	42	106	50	M-16	004 50 06 05 05	■	301 01 02 16 30
3	25	(ER25)	1 - 16	42	200	50	M-12	004 50 06 15 05	■	301 01 02 12 30
3	25	(ER32)	2 - 20	50	111	55	M-16	004 50 06 05 06	■	301 01 02 16 30
3	32	(ER32)	2 - 20	50	115	55	M-16	004 50 06 06 06	■	301 01 02 16 40
3	40	(ER32)	2 - 20	50	115	55	M-16	004 50 06 07 06	■	301 01 02 16 40
3	32	(ER40)	3 - 26	63	123	63	M-16	004 50 06 06 07	■	301 01 02 16 40
3	40	(ER40)	3 - 26	63	123	63	M-16	004 50 06 07 07	■	301 01 02 16 40

RELATIONATED ELEMENTS Page: 250
ELEMENTOS RELACIONADOS
VERWANDTE ARTIKEL



ACCESSORIES INCLUDED
ACCESORIOS INCLUIDOS
ZUBEHÖR ENTHÄLT

Conventional Convencional Standardausführung	Bearing shell nut Con casquillo giratorio Kugelgelagerte Ausführung	Notch free Lisa Nutenlose Mutter	Mini Mini
ER 16 004 99 01 08 03	ER 16 004 99 01 04 03	ER 16 004 99 01 10 03	ER mini 8 004 99 01 06 01
ER 25 004 99 01 03 05	ER 25 004 99 01 04 05	ER 25 004 99 01 10 05	ER mini 11 004 99 01 06 02
ER 32 004 99 01 03 06	ER 32 004 99 01 04 06	ER 32 004 99 01 10 06	ER mini 16 004 99 01 06 03
ER 40 004 99 01 03 07	ER 40 004 99 01 04 07	ER 40 004 99 01 10 07	
ER 50 004 99 01 03 08	ER 50 004 99 01 04 08		

OPTIONAL ACCESSORIES
ACCESORIOS OPCIONALES
OPTIONALES ZUBEHÖR

ER mini 8 004 99 04 05 01	ER 16 004 99 04 06 25	004 99 04 07 30
ER mini 11 004 99 04 05 02	ER 16 004 99 04 03 05	004 99 04 07 40
ER mini 16 004 99 04 05 03	ER 32 004 99 04 03 06	004 99 04 07 50

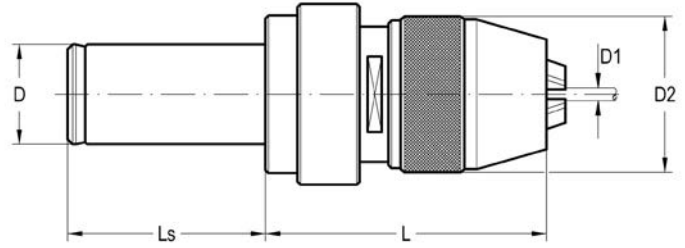

D h5	D1	D2	L	LS	COD.	Availability Disponibilidad Verfügbarkeit
32	1-13	48	89	60	012 50 09 16 13	■

SHRINK FIT EXTENSIONS
PROLONGADOR DE CONTRACCIÓN TÉRMICA
VERLÄNGERUNGEN FÜR SCHRUMPFUTTER

012 50 12 ...

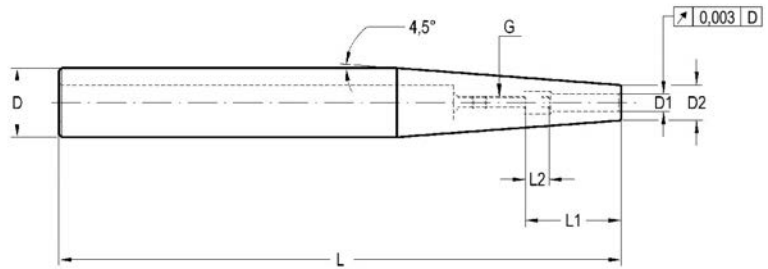

D h6	D1	L	D2	L1	L2	G	COD.	Availability Disponibilidad Verfügbarkeit	
12	3	160	8	20	-	-	012 50 12 32 03	■	-
12	4	160	9	20	-	-	012 50 12 32 04	■	-
12	5	160	10	25	-	-	012 50 12 32 05	■	-
16	3	160	8	20	-	-	012 50 12 33 03	■	-
16	4	160	9	20	-	-	012 50 12 33 04	■	-
16	5	160	10	25	-	-	012 50 12 33 05	■	-
16	6	160	12	36	14	M-5	012 50 12 33 06	■	301 02 33 05 02
16	8	160	14	36	10	M-6	012 50 12 33 08	■	301 02 33 06 02
20	3	160	8	20	-	-	012 50 12 34 03	■	-
20	4	160	9	20	-	-	012 50 12 34 04	■	-
20	5	160	10	25	-	-	012 50 12 34 05	■	-
20	6	160	12	36	10	M-5	012 50 12 34 06	■	301 02 33 05 02
20	8	160	14	36	10	M-6	012 50 12 34 08	■	301 02 33 06 02
20	10	160	16	42	10	M-8	012 50 12 34 10	■	301 02 33 08 02
20	12	160	18	47	10	M-10	012 50 12 34 12	■	301 02 33 10 02
25	10	200	16	41	10	M-8	012 50 12 55 10	■	301 02 33 08 02
25	12	200	18	46	10	M-10	012 50 12 55 12	■	301 02 33 10 02
25	14	200	20	46	10	M-10	012 50 12 55 14	■	301 02 33 10 02
25	16	200	22	49	10	M-12	012 50 12 55 16	■	301 02 33 12 02
32	12	200	18	47	10	M-10	012 50 12 56 12	■	301 02 33 10 02
32	14	200	20	50	10	M-10	012 50 12 56 14	■	301 02 33 10 02
32	16	200	22	50	10	M-12	012 50 12 56 16	■	301 02 33 12 02
32	18	200	24	52	10	M-12	012 50 12 56 18	■	301 02 33 12 02
32	20	200	26	52	10	M-16	012 50 12 56 20	■	301 02 33 16 02

- For tool shanks according to DIN 6535 form HA and DIN 1835-1 form A.

- Para herramientas con mango DIN 6535 forma HA y DIN 1835-1 forma A.

Bei VHM- oder HSS – Werkzeugen.

Delivery:

- With built-in bored through stop screw.
- Other sizes and profiles on request.

Suministro:

- Con tornillo de regulación con orificio de paso de refrigerante.
- Otras formas y tamaños bajo demanda expresa.

Lieferung:

- Mit eingebauter durchgebohrter Anschlagsschraube.

FRONT CONTACT CYLINDRICAL EXTENSIONS FOR SCREW IN-TOOLS

PROLONGADORES DE MANGO CILÍNDRICO PARA MANGOS ROSCADOS CON APOYO FRONTAL
EINSCHRAUBFRÄSER VERLÄNGERUNG



012 50 57 ...

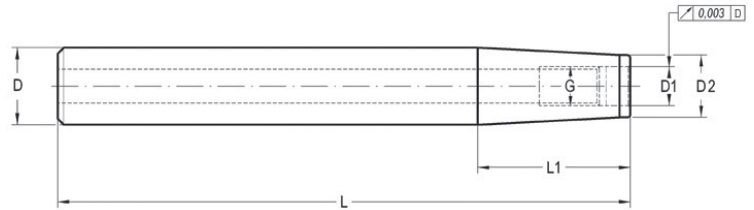

D h6	G	D2	D1	L	L1	COD.	Availability Disponibilidad Verfügbarkeit
12	M-6	9,8	6,5	160	40	012 50 57 32 01	■
16	M-8	12,8	8,5	160	45	012 50 57 33 02	■
20	M-10	17,8	10,5	160	50	012 50 57 34 03	■
25	M-12	20,8	12,5	160	55	012 50 57 35 04	■
32	M-16	28,8	17	160	60	012 50 57 36 05	■

Delivery:
- Cylindrical shaft according to DIN 6535 Form HA.

Suministro:
- Mango cilíndrico según DIN 6535 Forma HA.

Lieferung:
- Zylindrischer Schaft nach DIN 6535 Form HA.

RELATIONATED ELEMENTS Page: 212
 ELEMENTOS RELACIONADOS
 VERWANDTE ARTIKEL



003 57 57 ...



004 57 06 ...

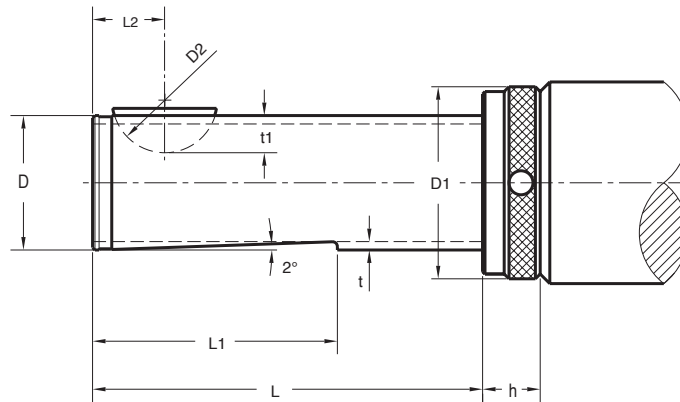

D g5	D1	L	L1	D2	L2	t	t1	h	
Tr 16 x 1,5	25	73	43	16	11	1,3	5,4	12	001 99 12 01 30
Tr 20 x 2	32	76	46	19	13	1,3	6,4	12	001 99 12 01 03
Tr 25 x 2	37	83	51	22	15	1,5	7,5	12	001 99 12 01 40
Tr 28 x 2	40	83	51	22	15	1,5	7,5	12	001 99 12 01 40
Tr 32 x 2	45	106	68	28	20	1,7	9,5	12	001 99 12 01 60
Tr 36 x 2	50	104	65	28	20	1,7	9,5	14	001 99 12 01 60
Tr 48 x 2	67	126	76	32	24	2,2	11,1	18	001 99 12 01 09

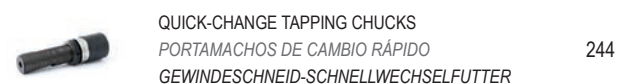
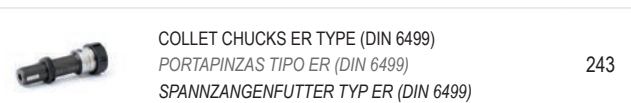
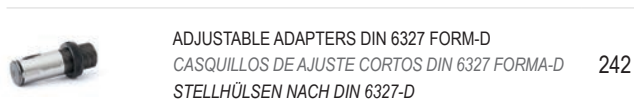

Material

Case-hardening alloy steel.
 Case-hardened and tempered.
 Minimum strength in core 880 N/mm²
 Surface hardness HRC 57 ÷ 60

Material

Acero aleado de cementación.
 Cementado y templado.
 Resistencia mínima al núcleo 880 N/mm²
 Dureza superficial HRC 57 ÷ 60

Material

Hochlegierter Stahl
 Einsatzgehärtet
 Zugfestigkeit im Kern: mind. 880 N/mm²
 Oberflächenhärte: HRC 57-60

ADJUSTABLE ADAPTERS DIN 6327 FORM-D
CASQUILLOS DE AJUSTE CORTOS DIN 6327 FORMA-D
KURZSTELLHÜLSEN NACH DIN 6327 FORM -D



003 51 11 ...

For tapered Morse taper tools DIN 228-B.
 Para herramientas con lengüeta DIN 228-B.
 Für MK- Werkzeuge mit Austreibblappen nach DIN 228-B.

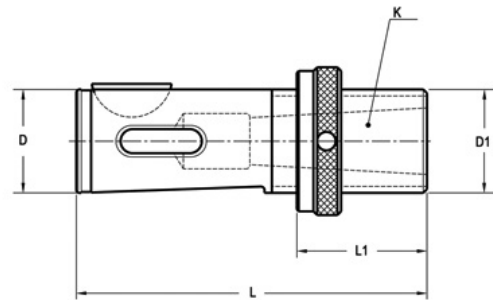

D	K	D1	L	L1	COD.	Availability Disponibilidad Verfügbarkeit	
16	M0	16	85	12-40	003 51 11 03 10	<input type="checkbox"/>	001 99 14 01 03
25	M1	25	95	12-42	003 51 11 05 20	<input type="checkbox"/>	001 99 14 01 05

Circular deviation between K and D1 ≤ 0,01

Desviación circular entre K y D1 ≤ 0,01

Rundlaufabweichung zwischen K und D1 ≤ 0,01

ACCESSORIES INCLUDED
ACCESORIOS INCLUIDOS
ZUBEHÖR ENTHÄLT



001 99 14 01 ..

OPTIONAL ACCESSORIES
ACCESORIOS OPCIONALES
OPTIONALES ZUBEHÖR



001 99 24 01 ..

COLLET CHUCKS ER TYPE (DIN 6499)
PORTAPINZAS TIPO ER (DIN 6499)
SPANNZANGENFUTTER TYP ER (DIN 6499)



004 51 06 ...

For tools with cylindrical straight shank DIN 1835-A.
 Para herramientas con mango cilíndrico liso DIN 1835-A.
 Für Werkzeuge mit zylindrischem Schaft DIN 1835-A.

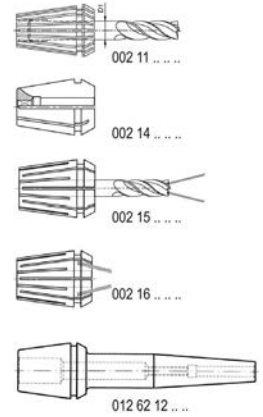
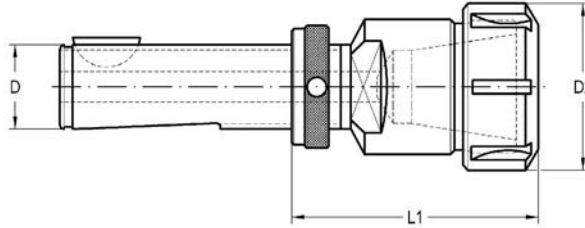

D	Size	D1 max	L1	D2	COD.	Availability Disponibilidad Verfügbarkeit	
28	(ER32)	20	70-98	50	004 51 06 06 06	■	001 99 14 01 06
48	(ER40)	26	90-135	63	004 51 06 09 07	■	001 99 14 01 09

RELATIONATED ELEMENTS Page: 250
ELEMENTOS RELACIONADOS
VERWANDTE ARTIKEL



ACCESSORIES INCLUDED
ACCESORIOS INCLUIDOS
ZUBEHÖR ENTHÄLT

Conventional
Convencional
Standardausführung



ER 32 004 99 01 03 06
 40 004 99 01 03 07

Bearing shell nut
Con casquillo giratorio
Kugellagerte Ausführung



ER 32 004 99 01 04 06
 40 004 99 01 04 07

Notch free
Lisa
Nutenlose Mutter



ER 32 004 99 01 10 06
 40 004 99 01 10 07

OPTIONAL ACCESSORIES
ACCESORIOS OPCIONALES
OPCIONALES ZUBEHÖR



ER 32 004 99 04 03 06
 40 004 99 04 03 07



004 99 04 07 40
 004 99 04 07 50

HSK
 DIN 69871
 BT
 BT_DUAL CONTACT
 POLYGONAL TAPER_LC6
 DIN 2080
 MORSE QUICK CHANGE
 MODULAR
 FINE MACHINING
 R-8 STRAIGHT DIN 63 27/1835

QUICK-CHANGE TAPPING CHUCKS
PORTAMACHOS DE CAMBIO RÁPIDO
GEWINDESCHNEID-SCHNELLWECHSELFUTTER



019 51 52 ...

With self feed and compression system. For BILZ system tap adapter.
 Doble compensación axial. Para sistema BILZ.
 Mit Längenausgleich auf Zug und Druck. Geeignet für BILZ-Schnellwechseleinsätze.

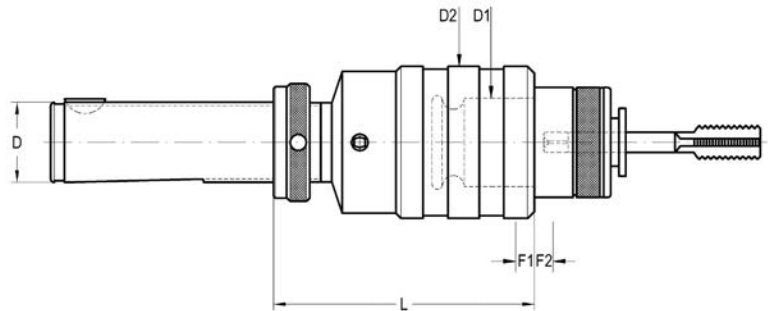

D	CAP.	D1	L	D2	F1	F2	COD.	Availability Disponibilidad Verfügbarkeit
20	M3-M12 (M16)*	19	52	36	7,5	7,5	019 51 52 04 02	■
28	M3-M12 (M16)*	19	52	36	7,5	7,5	019 51 52 06 02	■
36	M8-M20 (M30)*	31	78	53	12,5	12,5	019 51 52 08 03	■

- F1 Compression run.
 - F2 Extension run.
 * With 002 22 ... and 002 24 ... adapters.

- F1 Recorrido de compresión.
 - F2 Recorrido de extensión.
 * Con adaptadores 002 22 ... y 002 24 ...

- F1 Druck
 - F2 Zug
 * Mit Einsätzen gem. Art-Nr. 002 22... und 002 24... ..

RELATIONATED ELEMENTS Page: 250
ELEMENTOS RELACIONADOS
VERWANDTE ARTIKEL



FORM B

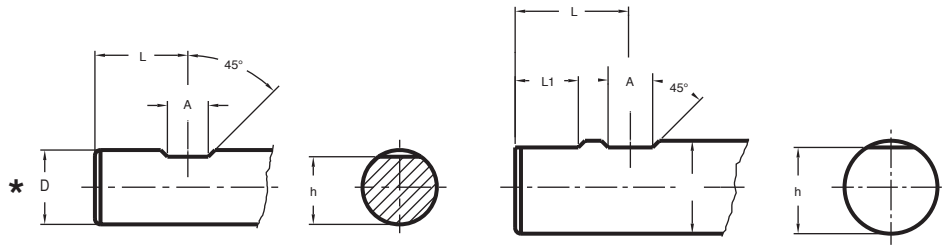

D h6	A	L	L1	h h13
*20	11	25	-	18,2
25	12	32	17	23
32	14	36	19	30

FORM E

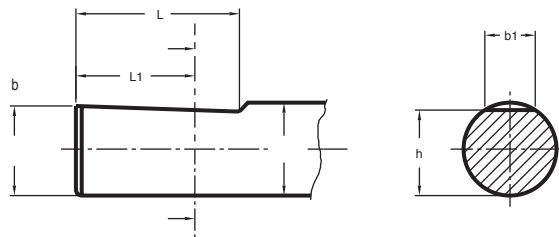

D h6	L	L1	b	b1 h13	h h13
*20	11	25	19,1	11,5	18,2
25	12	32	24,1	13,6	23
32	14	35	31,2	15,5	30



REDUCING ADAPTERS FOR WELDON OR WHISTLE NOTCH HOLDERS
 REDUCTORES WELDON OR WHISTLE NOTCH
 REDUZIERUNGSHÜLSE FÜR WELDON UND WHISTLE NOTCH

246



QUICK-CHANGE TAPPING CHUCKS
 PORTAMACHOS DE CAMBIO RÁPIDO
 GEWINDESCHNEID-SCHNELLWECHSELFUTTER

247

Material

Case-hardening alloy steel.
 Case-hardened and tempered.
 Minimum strength in core 880 N/mm²
 Surface hardness HRC 57 ÷ 60

Material

Acero aleado de cementación.
 Cementado y templado.
 Resistencia mínima al núcleo 880 N/mm²
 Dureza superficial HRC 57 ÷ 60

Material

Hochlegierter Stahl
 Einsatzgehärtet
 Zugfestigkeit im Kern: mind. 880 N/mm²
 Oberflächenhärte: HRC 57-60

REDUCING ADAPTERS FOR WELDON OR WHISTLE NOTCH HOLDERS

REDUCTORES WELDON OR WHISTLE NOTCH

FLÄCHENSPANNFUTTER WELDON UND WHISTLE NOTCH

012 55 01 ...



For end mills with shank DIN 1835-B - DIN 6535 HB.

Para fresas con mango cilíndrico con encaste DIN 1835 forma B y DIN 6535 forma HB.

Für Werkzeuge mit zylindrischem Schaft nach DIN 1835-B/DIN 6535 HB oder 1835-E/DIN 6535 HE.

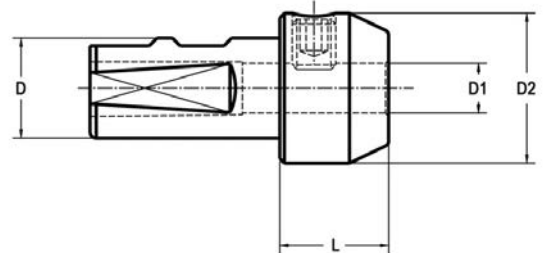

D	D1H5	L	D2	COD.	Availability Disponibilidad Verfügbarkeit	
20	6	35	25	012 55 01 05 06	■	301 01 05 06 10
20	8	35	28	012 55 01 05 08	■	301 01 05 08 10
20	12	50	42	012 55 01 05 12	■	301 01 05 12 16
25	6	35	25	012 55 01 06 06	■	301 01 05 06 10
25	8	35	28	012 55 01 06 08	■	301 01 05 08 10
25	10	35	35	012 55 01 06 10	■	301 01 05 10 12
25	12	35	42	012 55 01 06 12	■	301 01 05 12 16
25	14	56	44	012 55 01 06 14	■	301 01 05 12 16
25	16	60	48	012 55 01 06 16	■	301 01 05 14 16
32	6	30	25	012 55 01 07 06	■	301 01 05 06 10
32	8	30	28	012 55 01 07 08	■	301 01 05 08 10
32	10	35	35	012 55 01 07 10	■	301 01 05 10 12
32	12	35	42	012 55 01 07 12	■	301 01 05 12 16
32	14	35	44	012 55 01 07 14	■	301 01 05 12 16
32	16	35	48	012 55 01 07 16	■	301 01 05 14 16
32	18	60	50	012 55 01 07 18	■	301 01 05 14 16
32	20	62	52	012 55 01 07 20	■	301 01 05 16 16

QUICK-CHANGE TAPPING CHUCKS
PORTAMACHOS DE CAMBIO RÁPIDO
GEWINDESCHNEID-SCHNELLWECHSELFUTTER

019 55 52 ...



With self feed and compression system. For BILZ system tap adapter.
 Doble compensación axial. Para sistema BILZ.
 Mit Längenausgleich auf Zug und Druck. Geeignet für BILZ-Schnellwechseleinsätze.

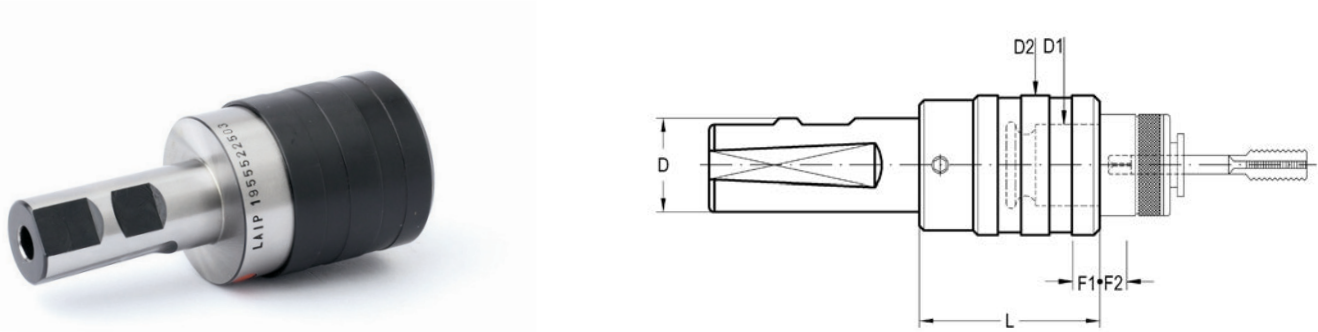

D	CAP.	D1	L	D2	F1	F2	COD.	Availability Disponibilidad Verfügbarkeit
20	M3-M12 (M16)*	19	39	36	7,5	7,5	019 55 52 20 02	■
25	M3-M12 (M16)*	19	39	36	7,5	7,5	019 55 52 25 02	■
25	M8-M20 (M30)*	31	63	55	12,5	12,5	019 55 52 25 03	■
32	M8-M20 (M30)*	31	63	53	12,5	12,5	019 55 52 32 03	■
32	M14-M33 (M48)*	48	124	78	20	20	019 55 52 32 04	■

- F1 Compression run.
 - F2 Extension run.

* With 002 22 and 002 24 adapters.

- F1 Recorrido de compresión.
 - F2 Recorrido de extensión.

* Con adaptadores 002 22 y 002 24

- F1 Druck
 - F2 Zug

* Mit Einsätzen gem. Art-Nr. 002 22... .. und 002 24... ..

RELATIONATED ELEMENTS Page: 250
ELEMENTOS RELACIONADOS
VERWANDTE ARTIKEL



